

**DISPLAY L.P.**  
Digital process display 4 - 20 mA  
User manual



## Contents

<b>1 Safety guidelines</b> .....	<b>3</b>
<b>2 Intended use</b> .....	<b>4</b>
<b>3 Specifications</b> .....	<b>5</b>
<b>4 Functional description</b> .....	<b>6</b>
<b>5 Installation and operation</b> .....	<b>7</b>
5.1 Installation.....	7
5.2 Operating mode.....	7
5.3 Programming mode .....	9
<b>6 Maintenance</b> .....	<b>12</b>
<b>7 Transportation and storage</b> .....	<b>13</b>
<b>8 Package content</b> .....	<b>14</b>
<b>Annex A. Dimensions</b> .....	<b>15</b>
<b>Annex B. Electrical connection</b> .....	<b>16</b>

## Safety guidelines

---

### 1 Safety guidelines

Please read through the operating manual carefully before commissioning the device. Damages that arise from non-observance of the guidelines in the operating manual shall be devoid of any liability.

- The device may only be used in the manner described in this operating manual.
- No technical modifications may be made to the device.
- The device may not be used if the environmental conditions (temperature, humidity etc.) are not within the limits indicated in the specification.
- The device may not be used in explosive areas and there may be no chemically active substances in the air.
- The device should only be cleaned with a damp cloth. No abrasives or solvent-based cleaners should be used.

Non-observance of the safety guidelines may result in damage to the device and injury to users.

## Intended use

---

### 2 Intended use

The DISPLAY L.P. is a universally applicable, digital display unit. It is designed to be connected to any transmitter with a 4 - 20 mA output. The device requires no auxiliary power and is supplied directly from the measured current.

The field of application of the device includes the control and monitoring of industrial processes. The display can be used in automated systems as a primary or secondary display.

The device may only be operated

- properly installed and
- in accordance with the specification.

### Improper use

- The DISPLAY L.P. may not be used for medical devices that sustain, monitor or otherwise affect human life or health.
- The device may not be used in potentially explosive environment.
- The device may not be used in an atmosphere with chemically active substances.

## Specifications

---

### 3 Specifications

Table 1



Supply current	from current loop
Input signal	4 - 20 mA (2-wire)
Inputs	1
Measuring range	3.8 - 22.5 mA
Normal operation	3.2 - 25 mA
Voltage drop	≤ 7 V at 20 mA
Dynamic input resistance	≤ 200 Ohm
Accuracy	0.2% + 1 digit
Display	LED, 7-segment display
Character height	14 mm
Display colour	red or green
Number of digits in display	4
Sampling rate (without damping)	1 reading / s
IP Code	front IP65, rear IP20
Dimensions	48 x 26 x 65 mm
Weight	30 g approx.
Protection class	III
Operating temperature	-30 to +70 °C
Storage temperature	-40 to +80 °C
Humidity	up to 80% (non-condensing)

## Functional description

---

### 4 Functional description

A 4-digit, 7-segment LED display with 14 mm character height is located on the front of the device for displaying the measured values, error messages, functions and values during programming. The programming buttons are positioned on the cylindrical surface of the device.

The **PROG** button is used to set the programming mode and to apply the changes. The parameters can be selected and changed using buttons  and . Pressing and holding the buttons increases the speed of parameter changing in three steps.

The operating modes are described in Section 5.

The device has the following functions:

- Display physical parameters, received from process control devices with 4 - 20 mA output signals (current loop).
- The measured values are displayed on the 4-digit LED display with a maximum range of -999 to +9999 in accordance with the set limit values and the decimal point position.
- When exceeding the measuring limit, the device displays an error message.
- Switching between linear and square root function (for special transmitters)
- Filter for damping the signal fluctuations with an adjustable time constant
- Password protection against unauthorised access

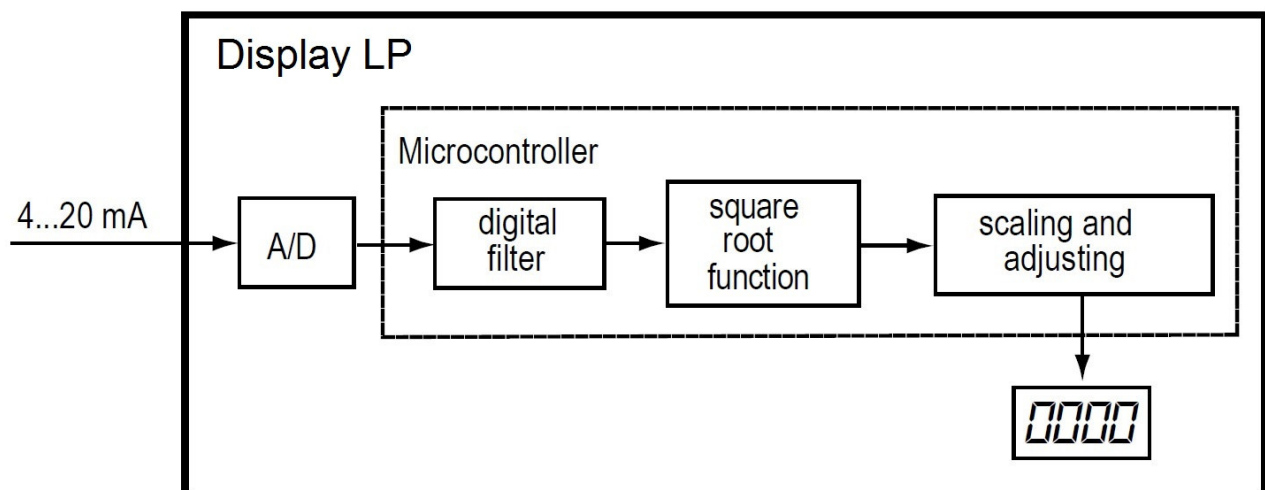

Fig. 1 Block diagram

### 5 Installation and operation

#### 5.1 Installation

The device is designed for switch panel mounting in a borehole of  $\varnothing 22.5$  mm (see Annex A for dimensional drawings).

Carefully position the supplied gasket on the display rear surface. Insert the cylindrical part of the device into the borehole and tighten the nut from the rear side of the switch panel. Connect the device to the signal cable in accordance with Annex B.

The device factory settings can be changed before assembly if necessary. For this purpose the display must be connected to a standard signal 4 - 20 mA.

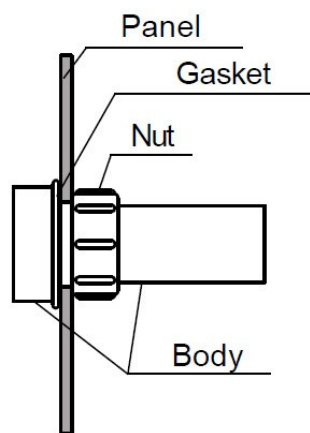

Fig. 2 Mounting 1

#### 5.2 Operating mode

The operating mode is automatically switched on if the standard signal 4 - 20 mA is connected to the terminals.

The input signal is digitalised, the square root calculated (if the function is enabled) and the signal accordingly to the set parameters calibrated and displayed. The scale factor is calculated based on the parameter **di.Lo** "lower limit" (according to input signal 4 mA) and **di.Hi** "upper limit" (according to input signal 20 mA).

If the input signal is lower than 3.8 mA, the error message **Lo** is displayed.

If the input signal is higher than 22.5 mA, the error message **Hi** is displayed.

##### **Square root function**

This function is intended for transmitters with square characteristic curve. To enable the function, the parameter **Sqrt** must be set to **ON**.

##### **Damping function**

Undesirable signal fluctuations can be suppressed through the adjustable filter constant.

The most important feature of the exponential filters is **Td** – the filter time constant (parameter **td**) (see Fig. 3 and Table 2).

If the constant increases, the display reacts to changes of the input signal more slowly and the susceptibility to interference is lower.

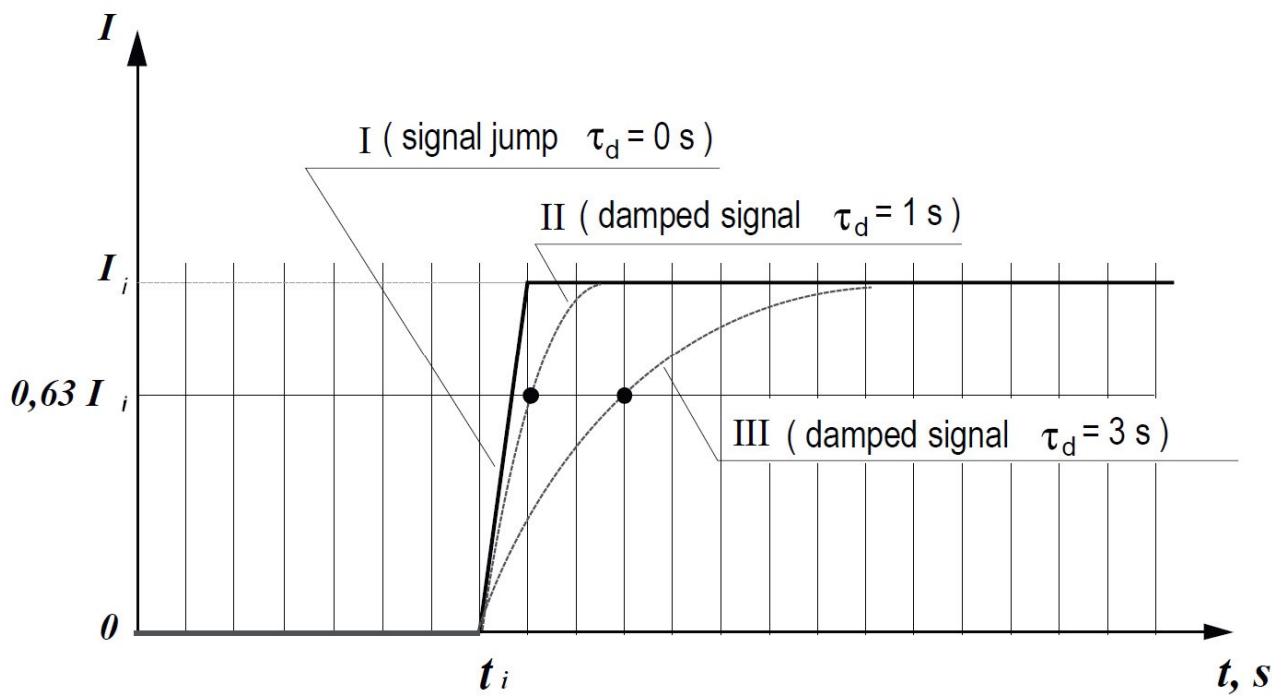

Fig. 3



## Installation and operation

### 5.3 Programming mode

In programming mode the necessary parameters can be changed (see Table 2).

To return to the operating mode, the  button must be pressed for longer than 5 s. If no button is pressed within 20 s, the device reverts to operating mode automatically. The flowchart is presented in Fig. 4.

Table 2

Parameter	Komments	Valid values
<b>PS</b>	Password protection	<b>on</b> <sup>1)</sup>
		<b>oFF</b>
<b>di.P</b>	Decimal point position (from the right)	- - - - .
		- - - - .
		- - - - .
		- - - - .
<b>di.Lo</b>	Lower limit (with 4 mA)	<b>-999...4.00...9999</b> <sup>2)</sup>
<b>di.Hi</b>	Upper limit (with 20 mA)	<b>-999...20.00...9999</b> <sup>3)</sup>
<b>td</b>	Filter time constant in seconds	<b>0...1...10</b>
<b>Sqrt</b>	Square root function on/off	<b>on</b>
		<b>oFF</b>

#### Comments:

1. Factory settings are highlighted.
2. With particular setting parameters the device cannot display the necessary minus sign due to the restriction to four segments. The parameters are configured as follows:  
**di.Lo:** -999 → 4 mA  
**di.Hi:** 9999 → 20 mA  
With an input measured current of 3.8 mA the correct display should be “-1068”. Due to the restriction to four segments, the minus sign is removed and the display is “1068”.
3. With particular setting parameters the device cannot actually display the necessary 5 figures due to the restriction to four segments. The parameters are configured as follows:  
**di.Lo:** -999 → 4 mA  
**di.Hi:** 9999 → 20 mA  
With an input measured current of 20.8 mA the correct display should be “10548”. Due to the restriction to four segments, the first character is removed and the display is “0548”.

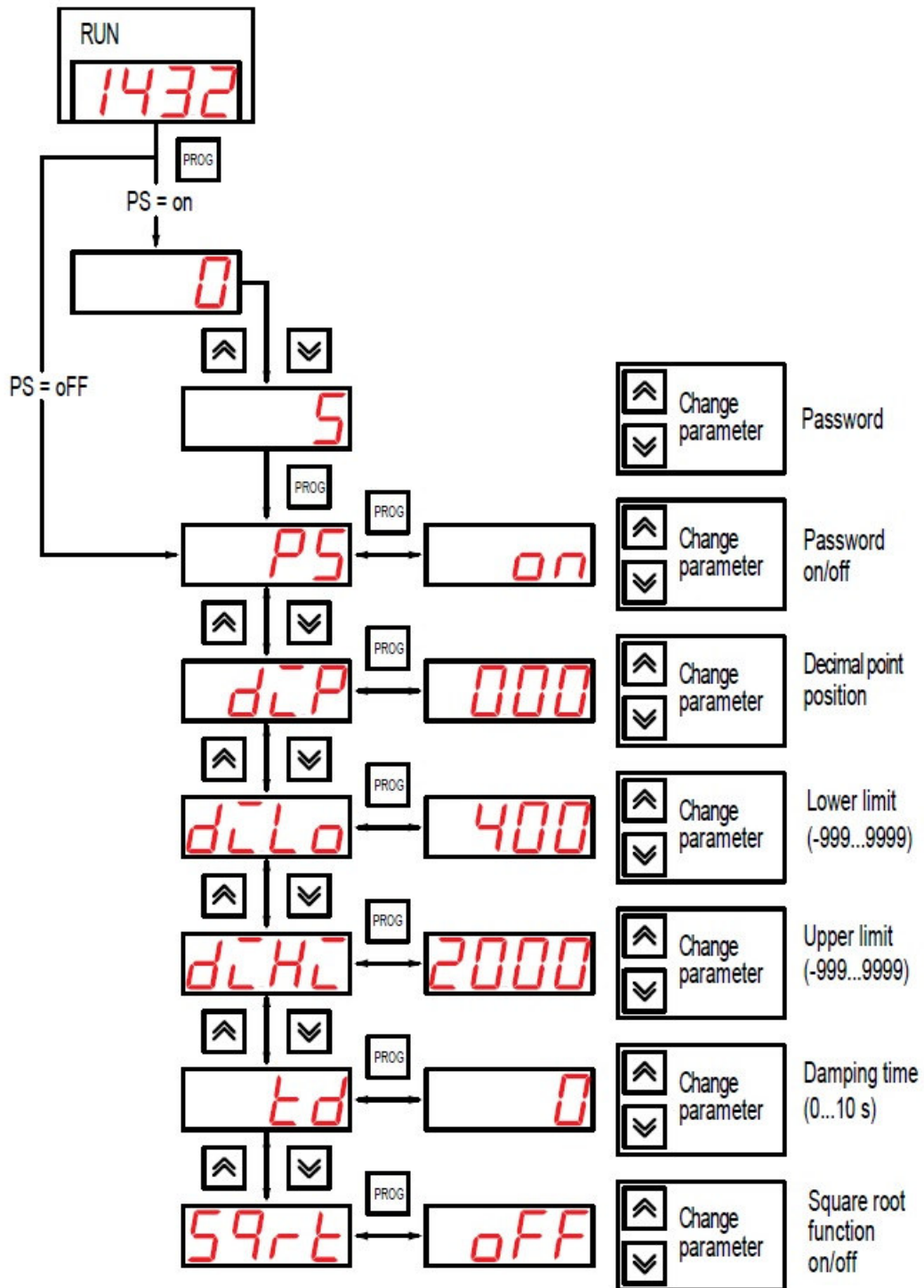





Fig. 4



## Installation and operation

---

To enter the programming mode use the button .

To scroll the parameters use the buttons  and  to change the parameter use the button .

When the device is switched on for the first time or the password protection is activated, **0** is displayed.

Use the buttons  and  to enter the correct password (factory setting – **5**), then press the  button to confirm.

If an incorrect password is entered, the device reverts to operating mode.

If the  password protection is disabled (the parameter **PS** is **OFF**), the password is not requested.

If the  button is pressed while the parameter **PS** is being displayed, the following characters appear on the display: **I- - - -**. This means that the upper end of the menu has been reached.

If the  button is pressed while the parameter **Sqrt** is being displayed, the following characters appear on the display: **- - - -I**. This means that the lower end of the menu has been reached.

Briefly push the  button (< 1 s) to change the selected parameter. The display indicates the actual parameter value. The factory settings are shown in Fig. 4 and Table 2. The value can be changed using



buttons  and . After confirming by pressing the  button, you return to the parameter list. Potential errors and troubleshooting measures are listed in Table 3.

Table 3 Error display

Display	Possible cause of error	Remedy
Lo (in operation)	Input current lower than 3.8 mA	Check input signal
Hi (in operation)	Input current higher than 22.5 mA	Check input signal
None	No input signal	Check input signal
	Reverse polarity on input	Check polarity

### 6 Maintenance

Technical maintenance should be performed on the device at least every 6 months by maintenance personnel and comprising the following tasks:

- Removing dust, dirt and foreign matter from the housing.
- Checking mounting of device
- Checking connections

The device should be cleaned with a damp cloth only. No abrasives or solvent-containing cleaners may be used.

The safety guidelines in Section 1 must be observed when performing maintenance.

## Transportation and storage

---

### 7 Transportation and storage

The device must be transported in closed transport boxes.  
Protective measures against shocks, vibrations and humidity must be observed.  
There may be no chemically active substances in the air.  
The storage temperature may lie between -40 and +80 °C.

## Package content

---

### 8 Package content

- Digital process display 1
- Gasket 1
- Mounting nut 1
- User manual 1

## Annex A. Dimensions

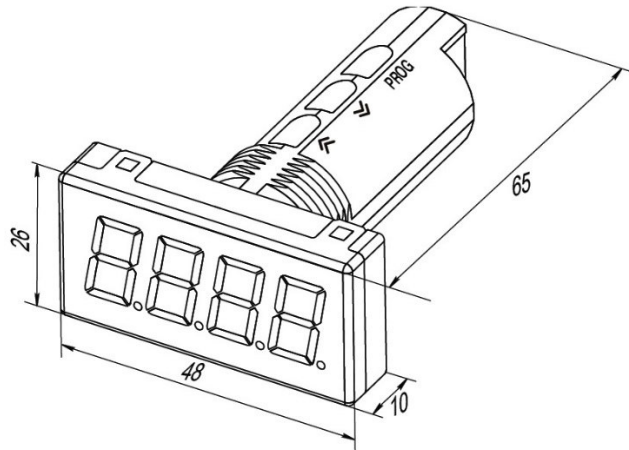

Fig. A.1

To prevent the device spinning, the borehole in the front panel must correspond to the dimensions in Fig. A.2.

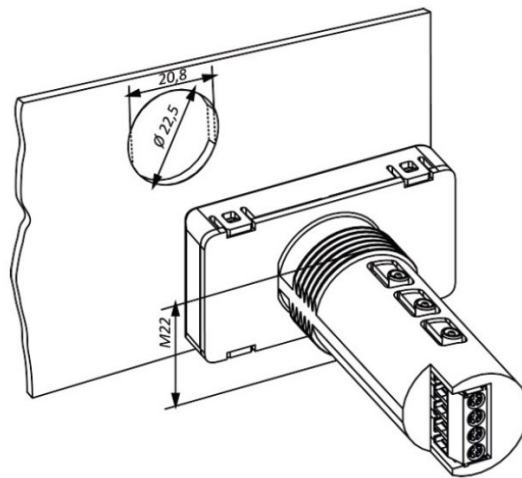

Fig. A.2

Annex B. Electrical connection

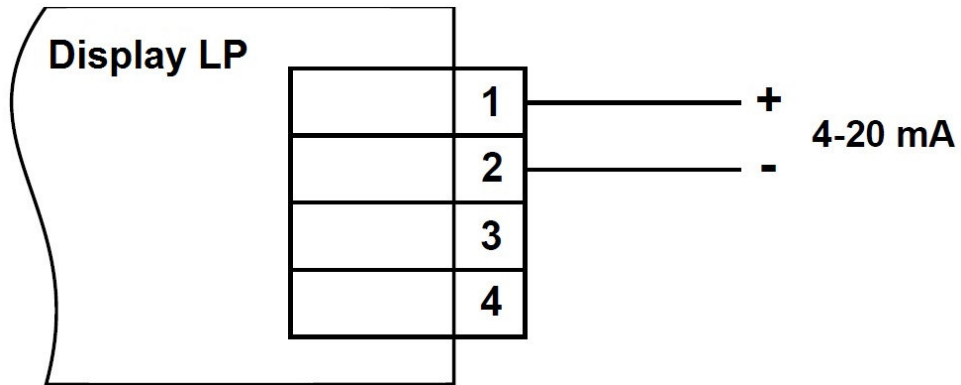

Fig. B.1

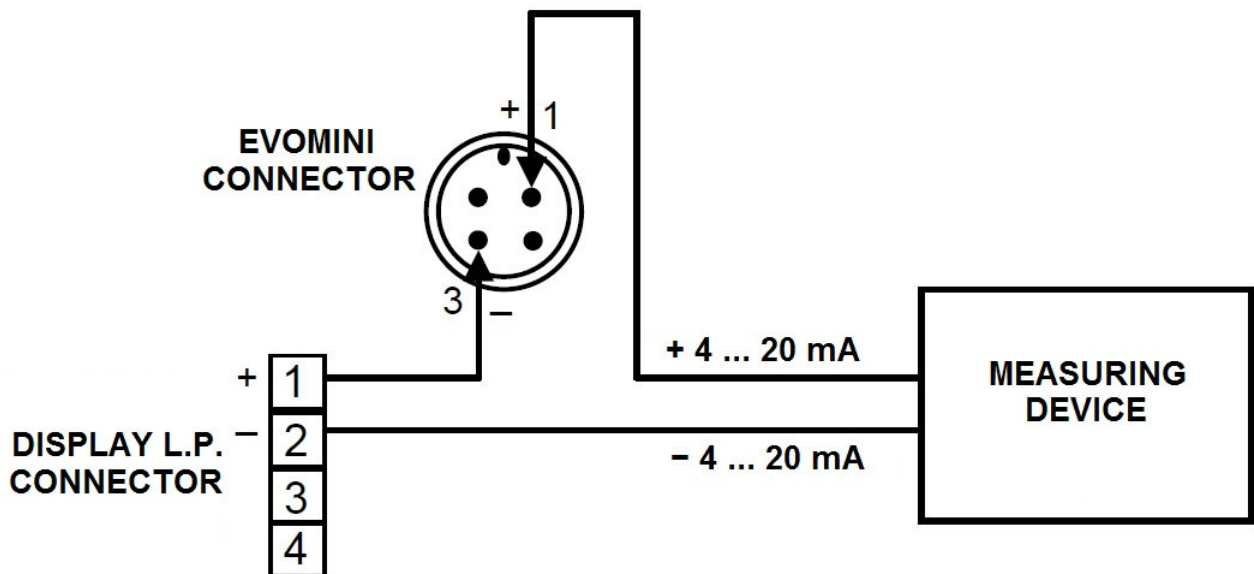

Fig. B.2



## 2021 ITALCOPPIE sensori s.r.l.

All rights reserved.

No part of this document may be reproduced or transmitted in any form, electronically or mechanically, or any purpose, without prior authorisation in writing by ITALCOPPIE SENSORI s.r.l.

ITALCOPPIE sensori s.r.l. takes the greatest pains to ensure that the information given in this document are correct. However, ITALCOPPIE sensori s.r.l. products are continually being improved; this may result in modifications without notification to the contents of this manual.

ITALCOPPIE sensori s.r.l. is not liable for technical and editorial errors or omissions in the material contained herein, nor for incidental or consequential damages resulting from the supply, performance or use of this material.

**Warranty:** We warrant that the products will be free from defects in material and workmanship for 1 years. The warranty above shall not apply for any failure caused by the use of the product not in line with the instructions reported on this manual.

**Product return:** the instruments can be returned under warranty only after Italcoppie sensori authorization.

ITALCOPPIE SENSORI s.r.l.  
Via A. Tonani, 10  
26030 Malagnino (Cremona) Italy  
Tel. +39 0372-441220  
Fax. +39 0372-441238  
<http://www.italcoppie.com>

This product must be disposed of according to the European WEEE (Waste Electrical & Electronic equipment)

