

---

# EvominiSER



***Transmitter with Modbus RTU  
output signal and I<sup>2</sup>C digital  
sensors or RTD input***

## ***USER'S MANUAL***

---

## Summary

1	General safety rules .....	4
1.1	Recommendations for workers .....	4
1.2	Typical applications .....	4
1.3	Safety rules .....	4
2	Introduction .....	5
2.1	Working principle .....	5
3	Installation .....	6
3.1	Mounting instructions .....	6
3.2	Operating conditions .....	6
3.3	Electric connections .....	6
3.3.1	Power supply requirements .....	7
3.3.2	Pinout and connections .....	7
3.3.3	Cabling good practices .....	8
3.3.4	Polarity .....	9
3.3.5	Terminating impedance .....	9
3.3.6	Allowed maximum number for series connected transmitters .....	9
4	Mechanical dimensions .....	10
5	Technical data .....	11
5.1	LED indicators .....	12
6	Certifications .....	12
7	Options .....	13
7.1	Isolator / Serial repeater .....	13
7.2	Connection cables .....	14
7.3	Extension cables with M12 connectors .....	15
7.4	T distributor for digital transmission .....	15
7.4.1	T distributor for digital transmission with integrated extension cable .....	16
7.5	Wall fixing bracket .....	17
7.6	Configuration kit .....	17
8	Order code .....	18
9	Compatible sensors .....	19
9.1	Temperature and relative humidity sensor .....	19
9.2	Temperature sensor with magnetic connector .....	20
9.3	Sensor for ambient light .....	21
9.4	RTD temperature sensor .....	23
10	Modbus registers table .....	23
10.1	Modbus communication parameters .....	23
10.1.1	Modbus communication parameters description .....	24
10.2	Device parameters .....	25
10.2.1	Device parameters description .....	25
10.3	System parameters .....	27
10.3.1	System parameters description .....	27
10.4	Set sensor type .....	29
10.4.1	Set sensor type description .....	29
10.5	User data (available only on EvominiSER-RTD item) .....	29
10.5.1	User data description .....	30
10.6	Process data .....	31
10.6.1	Process data for temperature and relative humidity sensor .....	32
10.6.2	Process data for temperature and relative humidity sensor description .....	32
10.6.3	Process data for surface temperature sensor .....	33
10.6.4	Process data for surface temperature sensor description .....	33
10.6.5	Process data for Lux sensor .....	34
10.6.6	Process data for Lux sensor description .....	34

10.6.7	RTD temperature sensor process data .....	35
10.6.8	RTD temperature sensor process data description .....	35
10.6.9	Fast start of device at power-on .....	36
11.	Modbus coils table.....	36
11.1	Coil description .....	37
12	Modbus RTU.....	38
12.1	Introduction to Modbus protocol.....	38
12.2	Master-slave protocol model .....	38
12.3.1	CRC-16 .....	39
12.3.2	CRC16 flow chart.....	40
12.3.3	Message synchronization .....	40
12.4	Modbus function codes.....	41
12.4.1	Read coil/input status (01 or 02) .....	41
12.4.2	Read holding/input registers (03 or 04) .....	42
12.4.3	Force single coil (05).....	42
12.4.4	Preset single register (06).....	43
12.4.5	Preset multiple registers (16) .....	44
12.4.6	Modbus exception responses .....	45
13	EVO SER compatibility .....	46
13.1	How to set the EVO SER compatibility .....	46
14	Device setup with EvoPlatform .....	47
14.1	Configure EvominiSER .....	49
14.1.1	Set desired COM parameters and Modbus address .....	49
14.1.2	Evo miniSER information and setup.....	50
14.1.3	Online features.....	50
14.1.4	Data monitoring .....	51
14.1.5	Factory settings.....	51
14.1.6	Configuration file .....	54
15	Firmware update .....	55
15.1	Firmware update at the power-on device .....	57
15.2	Update Firmware from BOOT(red LED on after power-on device) .....	59
16	Troubleshooting.....	61
16.1	Communication errors .....	61
16.2	LEDs are off after device power up .....	61
16.3	ERR LED .....	61
16.4	PWR LED.....	61



***Read and carefully follow the instructions given in this manual***

## 1 General safety rules

*Before performing any operations on the device, read carefully the following recommendations:*

- ✘ Before hooking up the device, read the installation instructions given in this manual.
- ✘ To wire up the device, a proper wiring size must be chosen according to voltage and current specifications found in technical data.
- ✘ The device is not equipped with an ON/OFF switch. Therefore, it powers up immediately as soon as power is supplied to it.
- ✘ The device must be powered with DC voltage greater than 9V and lower than 32V. Higher voltages will cause device failure while lower voltages will not allow the device to work properly.
- ✘ Make sure that the working environment conditions falls within the range specified in chapter 6 'Technical data'
- ✘ The device is not designed for operation in hazardous atmospheres (i.e., flammable or explosive): its use in such conditions is therefore **prohibited**.
- ✘ The device is intended for industrial use only. Do not use the device in situations where compliance with strict safety precautions is required, such as applications directly or indirectly correlated with medical equipment.
- ✘ The device must not be disassembled or repaired by unauthorised people. Contact your local dealer for any repairs.

### 1.1 Recommendations for workers

When performing their tasks, workers should observe the following recommendations:

- ✘ Workers with specific qualifications for assigned tasks are required
- ✘ Workers must be authorised by the plant's owner/operator
- ✘ Workers must be familiar with federal/national regulations
- ✘ Before doing any action, workers must read and understand the instructions given in the manual and the supplementary documentation (if available and depending on the application)
- ✘ Workers must comply with the instructions and basic conditions

### 1.2 Typical applications

Typical applications include HVAC systems (heating, ventilation, and air conditioning), agriculture, incubators, cold rooms, standard measurements, seasoning rooms etc.

- ✘ Only use this device in full compliance with the general conditions listed in this manual and, if applicable, in the additional documentation.

#### **Improper use:**

***Italcoppie Sensori s.r.l. is not liable in any way for damage or injury caused by tampering, incorrect or improper use of the device.***

### 1.3 Safety rules

Refer to the relevant regulations.

## 2 Introduction

The EvominiSER is a programmable digital transmitter with Modbus RTU output. It can be connected to different sensors in order to detect different data, such as temperature, humidity, light etc. Two different versions can be ordered: the EvominiSER I2C, that can be connected with various supported I2C digital sensors and the EvominiSER RTD, that can be connected with RTD Pt100/Pt1000 2 or 3 or 4 wire connection.

In this manual the model with I2Cbus input will be mentioned as EvominiSER-I2C (item code EVO032) while the model with RTD input will be mentioned as EvominiSER-RTD (item code EVO040 for the model without sensor, EOSI # and ESTP # for models with integrated sensor).

By using a specific cable, several EvominiSER can be connected in series. One device only can be a master.

With its small size, low-cost, IP67 degree of protection, easy-cabling and use quality, it is an extremely interesting equipment for several applications in industrial environment (e.g., HVAC systems). Its M12 connectors allow for a fast and easy cabling feature.

Furthermore, by using this transmitter it is possible to implement modular systems. If one or more devices are to be added to the network, it will not be necessary to design again the measurement system. Thus, no added design costs are to be sustained.

The Modbus protocol is a very popular standard for field bus applications due to its reliability and capability of efficiently handling large data flows. With the Modbus implementation, the Evo series can be hooked up directly to the majority of commercially available PLC's and SCADA packages, with the option to connect these modules together with other devices (PLC's, operator panels, CNC equipment, etc...) over a single network.

### 2.1 Working principle

The EvominiSER block diagram is shown in Figure 1.

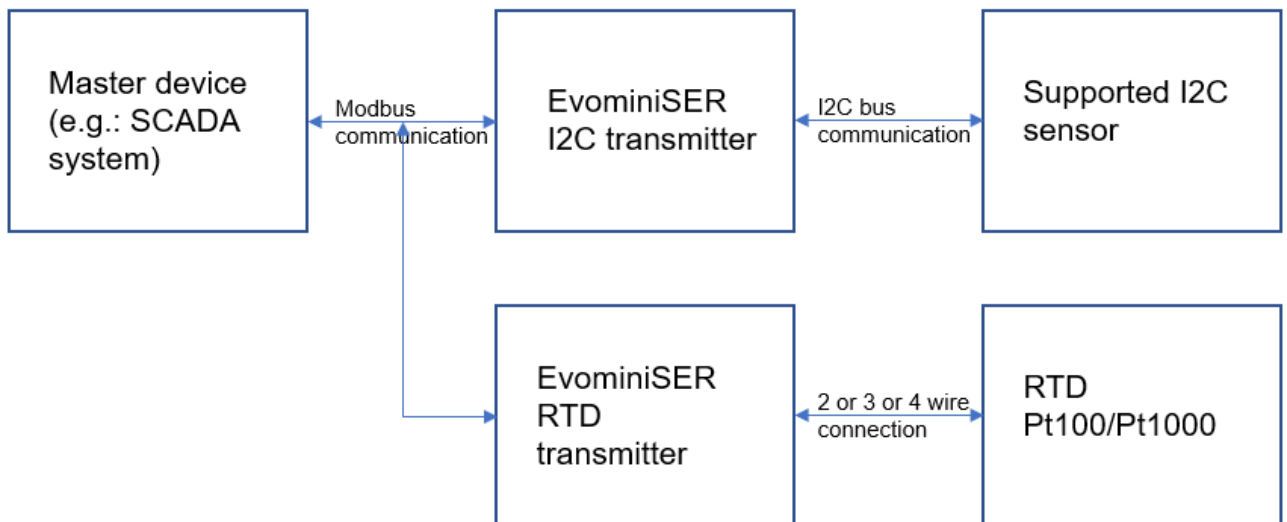

Figure 1: EvominiSER block diagram

A master unit, e.g., a PLC unit or a PC with SCADA (Supervisory Control And Data Acquisition) has to be connected to the network for data monitoring.

---

## 3 Installation

### **WARNING!**

***This device must be installed by qualified and authorized people.***

### 3.1 Mounting instructions

A picture of the EvominiSER is shown in Figure 2.



*Figure 2: EvominiSER*

In order to serially connect several transmitters, a specific M12 tee connector can be ordered together with its extension cables (for details refer to chapter 7).

A specific sensor can be connected using an M12 connector by screwing it to the metallic threaded ring. The connection is IP67.

"I2C" is marked on the body of the device to identify the EvominiSER model with input for digital sensors, "RTD" for the model with Pt100 or Pt1000 RTD input.

### 3.2 Operating conditions

**Installing ambient temperature:** (-40 ÷ +80) °C

**Installing ambient relative humidity:** (0 ÷ 100) %

**Protection degree:** IP67 according to IEC 60529

### 3.3 Electric connections

The EvominiSER comes with two 4-pole M12 connectors. A series connection of transmitters can be arranged by using an overmolded extension cable with a 4-pole M12 female connector. Tee connectors are available to extend the network. This solution allows for an IP65/IP67 connection. It is possible to use other commercially available female M12 connectors. In such a case, the degree of protection depends upon the cabling system.

### **WARNING!**

**The electric connections shall be executed as described in the following chapters. Cabling errors might break either the device or the entire devices' network.**

### 3.3.1 Power supply requirements

- ✘ Device power supply: typical  $24V_{DC}$ , or within  $(9 \div 32)V_{DC}$  range.
- ✘ Use a power supply with a  $24V_{DC}$  output, according to ELV regulations.
- ✘ Maximum current consumption: 10mA (at power-on for about 8 ms).
- ✘ Average current consumption: about 4mA.

On the power line, insert an insulation switch together with an appropriate fuse. The voltage supply must be continuous, isolated and with low ripple.

### 3.3.2 Pinout and connections

The pinout of the output connector is shown in Figure 3.

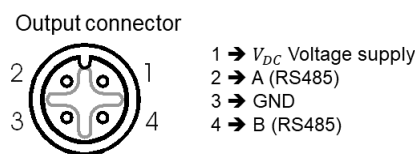

Figure 3: M12 male output connector pinout

#### **WARNING!**

- The device is protected against polarity inversion.
- In case of incorrect electrical wiring, the device is protected only for voltages less than  $25V_{DC}$ . A misconnection with higher voltages will cause a device failure.

The EvominiSER comes with half-duplex EIA RS-485 serial interface. The cabling is simplified by the M12 connectors<sup>1</sup>.

#### **WARNING!**

The device serial interface is not Galvanically isolated. If the master unit is equipped with RS232 serial interface, an isolated transceiver should be used. If the master unit is equipped with RS485 serial interface, a converter with Galvanic isolator should be used. As an option, a RS485 repeater/isolator can be ordered (cod. EVO005).

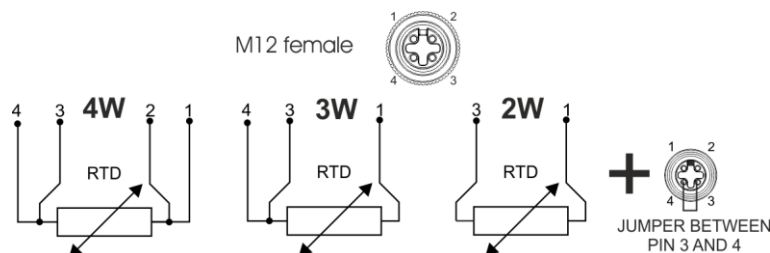

Figure 4a: RTD sensor connection, M12 female (for item EVO040 only)

Note: for 2W connection a jumper between pin 3 and 4 must be made (as close as possible to M12 female connector)

<sup>1</sup> 4-pin M12x1 male connector (according to IEC 61076-2-101)

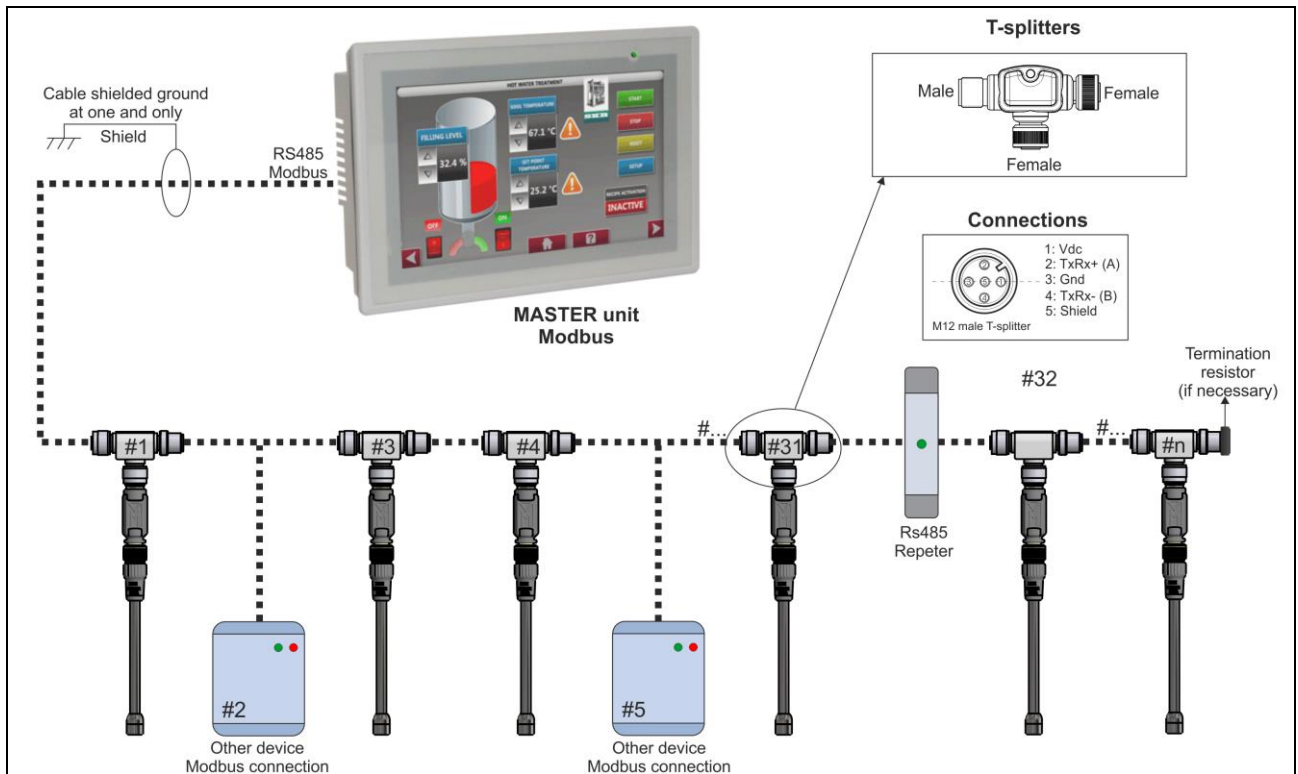

Figure 5: application example

### 3.3.3 Cabling good practices

The RS485 (EIA-485) is a standard defining the electrical characteristics of drivers and receivers for use in serial communications systems. Electrical signal is balanced, and multipoint systems are supported. Ideally, the two ends of the cable will have a termination resistor connected across the two wires. Without termination resistors, signal reflections off the unterminated end of the cable can cause data corruption. Termination resistor also reduce electrical noise sensitivity due to the lower impedance. The value of each termination resistor should be equal to the cable characteristic impedance (typically,  $120\Omega$  for twisted pairs). The master is usually already equipped with the termination resistance. The maximum length is not defined as depends upon the data rate, the signal-to-noise ratio and the cable quality.

There are some good practices that allows for external interference reduction. Cables that carry higher currents to power devices should be kept as far as possible from cables that carry communication signals. Cables reserved for communication signals must be kept as far as possible from power switching devices, such as contactors and relays, as well as from electric motors and generators. Choosing a cable suited for the particular application is also considered a good practice. In particular, the lower its capacitance per meter the longer the network can be. Typically, the cable should have a value within the range  $(50 \div 100)\mu\text{F/m}$ . The RS485 consists of two conductor cables and twisted pair cabling is suggested to ensure that each conductor is equally exposed to any external magnetic fields that could induce unwanted noise. A metallic electrostatic shielding is also suggested to provide immunity to RF interference.

A star topology network is not recommended. As explained above, a  $120\Omega$  termination impedance is required for the two end line termination devices to avoid reflections. Therefore, a very low impedance will result from a star topology network. Thus, no communication can result at a certain point.



---

### 3.3.4 Polarity

According to RS485/422 standard, the signal connections are indicated with A and B. However, it might be possible to find different indications on some products, such as HI/LO or +/- . If a device is unable to connect to the network, try inverting A and B and to connect the device again.

### 3.3.5 Terminating impedance

Signal reflections occur when a signal is transmitted along a transmission medium, such as a copper cable. Some of the signal power may be reflected back to its origin rather than being carried all the way along the cable to the far end. This happens because imperfections in the cable cause impedance mismatches and non-linear changes in the cable characteristics.

The signal reflections can be canceled by adapting the terminal impedance, whenever it is necessary. If the time required for a single bit transmission is, at least, ten times the signal propagation time on the network, the terminating impedance is not necessary.

The value of cable impedance depends on its dielectric material and mechanical dimensions. The velocity of propagation in PE cable is about 2/3 the speed of signal if the dielectric cable was vacuum. Therefore, the propagation time is:

$$t_p = \frac{1}{0.66 * c_0} * l$$

For example, for 9600baud and 1200m of cabling,  $t_p=6\mu s$ . The time required for a single bit transmission is:

$$t_{bit} = \frac{1}{\text{baud}(\frac{\text{bit}}{s})} = \frac{1}{9600} = 104\mu s$$

Thus, in this example, the terminating impedance is not strictly necessary. However, whenever the terminating impedance is required, a resistor must be inserted in the last node (from the master) between terminal A and B (pin 2 and pin 4 in the M12 connector). Its value must be equal to the cable impedance. In typical applications, the terminating impedance has only resistive components and its typical values are in the range 120Ω to 560Ω, depending on the cable and number of nodes on the network.

### 3.3.6 Allowed maximum number for series connected transmitters

The maximum number of transmitters that can be connected in series is dependent upon the connection length and cable parameters.

A calculation worksheet that indicates to the user the maximum number of devices that can be connected to an EvominiSER network given the cable cross-section (i.e., AWG) and cable length is available. It is downloadable from the website [products.italcoppie.it](http://products.italcoppie.it) (EvominiSER network data)

For example, with a 24V<sub>DC</sub> voltage supply and a 300m cabling:

- AWG20: up to 60 devices
- AWG22: up to 45 devices
- AWG24: up to 35 devices

The given indications refer to the given power supply. The RS485 transceiver can support up to 256 nodes, but it is suggested to place isolators/repeaters along the serial line. If the power supply cabling is longer than 100 meters, it is strongly suggested to use a MLCC capacitor (1000pF, 1kV; for example, RDE5C3A102J2M1H03A) connected between GND of the power supply and GND of the plant: this one is connected the cable shield.

## 4 Mechanical dimensions

The transmitter mechanical dimensions are shown in Figure 6/5a/5b.

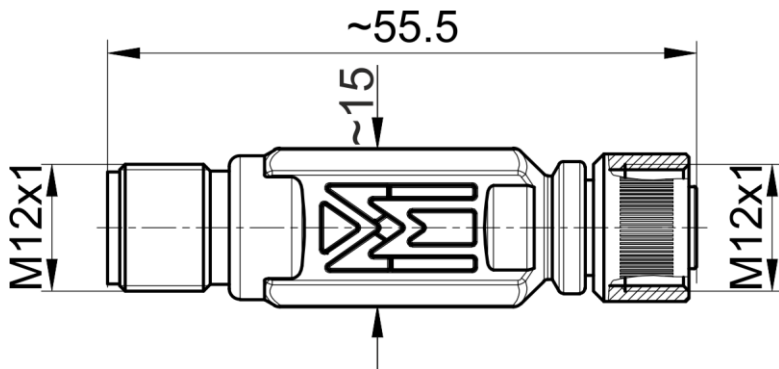

Figure 6: mechanical dimensions EVO032 / EVO040

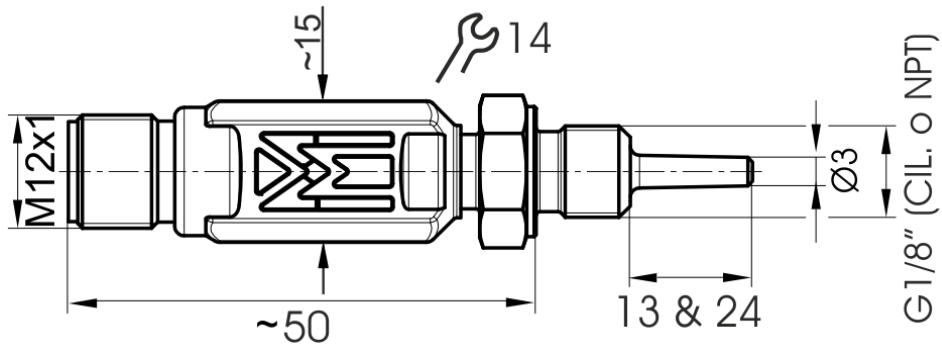

Figure 1a: mechanical dimensionis ESTP#

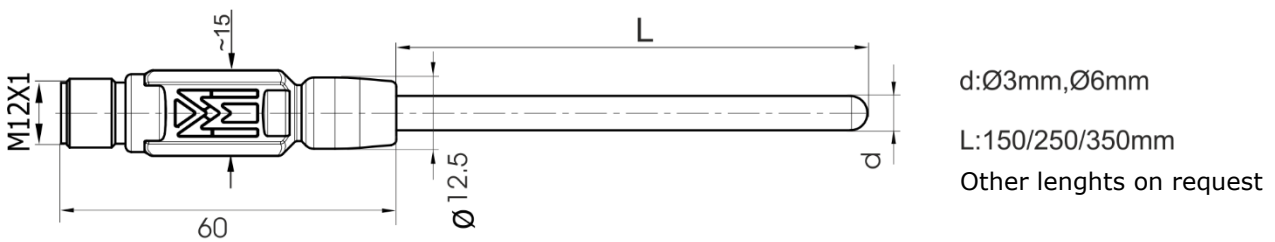

Figure 2b: mechanical dimensions EOSI#

(measure are in mm)

---

## 5 Technical data

### Power supply:

- $(9\div 32)V_{DC}$  (protected against polarity inversion)

### Current consumption:

- <4mA (working behavior), <10mA (at power-on for about 8ms)

### Transmitter operating temperature (with plastic body):

- $(-40\div 80)^{\circ}\text{C}$

### Output signal:

- Non-insulated serial interface (EIA RS-485 with RTU Modbus protocol)
- Baud rate settings: 9600bps, 19200bps, 38400bps
- Stop bit: 1 or 2
- Parity bits: none, even or odd
- Network length<sup>2</sup>: up to 1000m
- Max. nr. of devices: 256 (repeater/isolator is recommended along the serial line)

### Connection:

- Sensor: female 4-poles M12 connector for EVO032 and EVO040 (according to IEC 61076-2-101)
- Power supply + serial: 4-poles male M12 connector (according to IEC 61076-2-101)

### Body:

- Plastic body
- IP65/IP67 protection degree (according to IEC 60529)

### Marked indications:

- PWR blue LED with symbol indication "⏻" for device power status, red LED with **ERR** indication for either memory errors or boot mode operation, white LED with TX and RX indication, serial and batch number.

### The following features are for the EvominiSER-RTD model only





- Input: RTD Pt100 / Pt1000 ( $\alpha=0.00385$  /  $\alpha=0.003916$ ) connection 2, 3 or 4 wires
- RTD sensor range:
  - o EVO040 model:  $-200\div 850^{\circ}\text{C}$  (compatible with Italcoppie TRM# series)
  - o ESTP# model:  $-50\div 110^{\circ}\text{C}$
  - o EOSI# model:  $-50\div 350^{\circ}\text{C}$  (also available with sensing element for cryogenic environments up to  $-200^{\circ}\text{C}$ )
- Sensor excitation current:  $\sim 100\mu\text{A}$
- Accuracy:
  - o Converter:  $\leq \pm 0.2^{\circ}\text{C}$
  - o Sensing element: Class A (according to IEC751)
- Operating temperature influence on readout value:  $<\pm 0.25^{\circ}\text{C}/25^{\circ}\text{C}$  (deviation from  $20^{\circ}\text{C}$ )
- Resolution:  $0.1^{\circ}\text{C}$
- Sensor error compensation:  $\pm 10^{\circ}\text{C}$  on two points
- Maximum resistance of the sensor wire:
  - o 3-wire connection:  $20\Omega$  per wire
  - o 2-wire connection:  $40\Omega$  (total)
- Type of probe construction:
  - o AIS316L stainless steel for the ESTP# model

---

<sup>2</sup> The network length is dependent on the characteristics of the cable, on the power supply and on the number of connected devices (refer to chapter 3 for further details).

o With compact mineral insulation (M.I.C.), sheath material AISI 316L for the EOSI# model

## 5.1 LED indicators

	Blue PWR LED on: device is working correctly
	Blue PWR LED slow blinking (800mS): sensor not connected, broken or measurement error. Blue PWR LED fast blinking (200mS): sensor short circuit
	ERR LED on: BOOT mode activated (update firmware) ERR LED slow blinking (800mS): memory or functional error (refer to modbus register 40070)
	On data transmission white LED on
	On data reception white LED on
All LEDs on	Undetected or not compatible LEDs sensor at power on (only for EvominiSER-I2C)

For more details, refer to Modbus register **40070**

When the device is turned on, the blue PWR

LED flashes quickly for about 3 seconds\*; after that this led can indicate these conditions:



- LED on steady indicates that the device is powered and functioning correctly.
- A slow flash indicates a communication error between the transmitter and the sensor. (For EVO032 and EVO040 models check that the ferrule of the device is well screwed to the sensor; if the problem persists, contact technical assistance).

\*If the "Fast start" option is active, the blue LED does not flash but turns on immediately.

Only for EvominiSER-I2C:

- Blue, red and 2 white LEDs on at the same time: the sensor connected to the device is not compatible with the firmware. Download on the device the firmware compatible with the connected sensor, available on the products.italcoppie.it website. For further information, contact the local dealer.
- A quick flash of the blue LED indicates a short circuit condition detected on the sensor: in this case, the device must be immediately switched off.  
NOTE: if the device is not turned off, even if there is no longer a short circuit condition, the LED will continue to flash. If the problem persists, contact technical assistance

## 6 Certifications

Electromagnetic compatibility		Directive: Electromagnetic compatibility regulations 2016 Harmonization laws: BS EN 61326-1:2013
		Directive: 2014/30/EU Harmonization laws: EN 61326-1:2013
RoHS2		Directive: 2011/65/EU from 08-06-2011

## 7 Options

### 7.1 Isolator / Serial repeater

It allows for signal isolation and amplification between the RS485 serial port and the power supply of the EvominiSER.

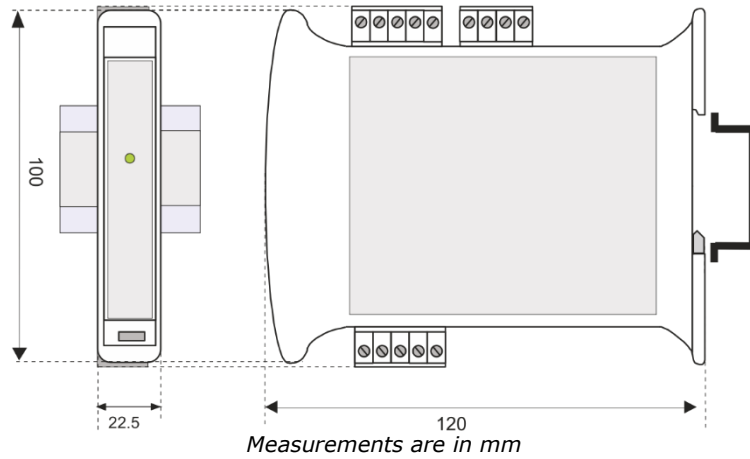

#### ISOLATION STRUCTURE

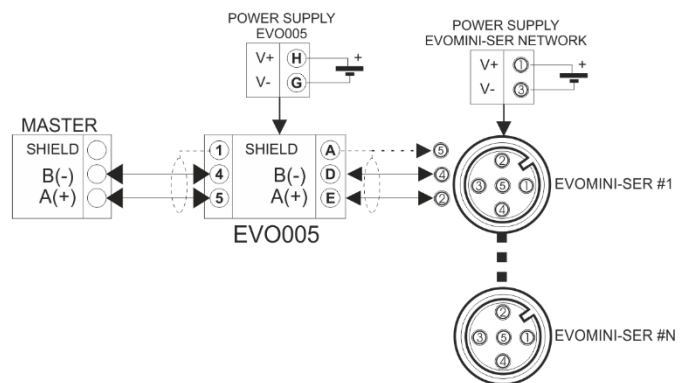
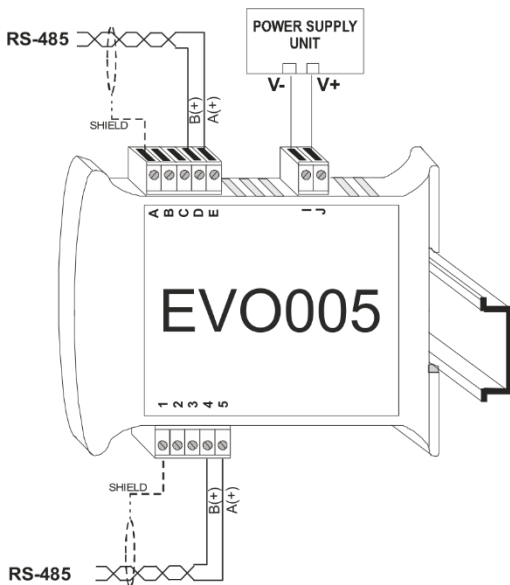

<i>Power supply</i>	$(10 \div 30)V_{DC}$
<i>Baud rate</i>	up to 115200 baud
<i>Internal terminator resistance (optional)</i>	120Ω
<i>Isolation:</i> <i>Power supply/RS485-422</i> <i>RS485-422/ RS485-422</i>	2000Vac, 50Hz, 1min 2000Vac, 50Hz, 1min
<i>Maximum distance / baud rate ratio (recommended)</i> <sup>3</sup>	1km @ 38400bps
<i>Current consumption</i>	35mA
<i>TX/RX switching time (RS485)</i>	150μs
<i>Operating temperature</i>	$(-20 \div 60) ^\circ\text{C}$
<i>Storage temperature</i>	$(-40 \div 85) ^\circ\text{C}$
<i>Relative humidity without condensation</i>	$(0 \div 90) \%$
<i>DIN rail compatible</i>	
<i>Automatic baud rate adaptation</i>	
<i>Serial connection mounting and removal contact</i>	
<i>Order code: EVO005</i>	

## 7.2 Connection cables

A specifically designed optional cable for Modbus serial networks is available as an option. It consists of two twisted cables (used for RS485 serial line) that allows greater noise rejection, and of two power cables with larger diameter to sustain higher currents. The two pairs of cables are shielded using an overall aluminum foil and a drain wire, allowing for an easy connection with M12 connectors. An external PVC jacket is used for cable enclosure. Cable characteristics are indicated in the following tables.

<b>Conductors</b>	
Conductors nr.	4 + drain wire and shield
Features	1 twisted pair AWG26 [serial signal] (0.14 mm <sup>2</sup> ) 1 pair AWG22 [power supply] (0.34 mm <sup>2</sup> )
Material	Copper
Color	1 twisted pair [serial]: white-light blue Pair [power supply]: red-black

<b>Shield foil</b>	
Material	Aluminum with drain wire

<b>Outer jacket</b>	
Material	PUR 92ShA -40÷90°C (static), Halogen free
Color	Matte grey
Diameter	$(5.1 \pm 0.2)\text{mm}$

<b>Electrical and mechanical data</b>	
Cables for static application	
Characteristic impedance at 1 MHz	$(87 \pm 10) \Omega$
Maximum capacitance	58pF/m
Resistance at 20°C	Twisted pair[serial signal]: 154.6Ω/km Pair [Power supply]: 64.2Ω/km

<sup>3</sup> The maximum distance depends on the number of devices connected, type of cabling, noises, etc.

Minimum bending cable		15 times the cable diameter	
Working temperature		(-40°C ÷ +90) °C (static)	
Maximum working voltage		300Vrms	
<b>Color code</b>			
$V_{IN}$	1	red	0.34 mm <sup>2</sup>
GND	3	black	
(A) RS485	2	white	0.14 mm <sup>2</sup> twisted cable
(B) RS485	4	light blue	
SHIELD	5	-	-

Order code: CAVV151

### 7.3 Extension cables with M12 connectors

Several extension cables are available with different lengths. The cable is described in chapter 7.2 and has two M12 5-pole connectors overmolded (straight or elbow outlet).

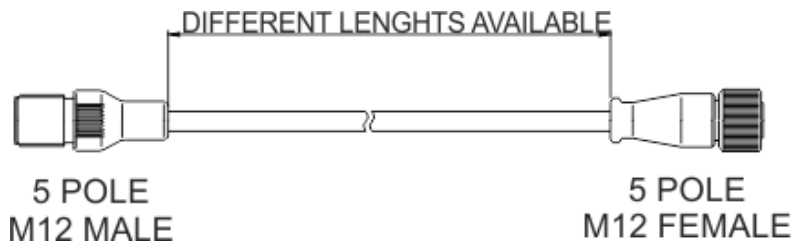

Order code\*: PRV#...

See the technical datasheet on [products.italcoppie.it](http://products.italcoppie.it) web site

### 7.4 T distributor for digital transmission

Tee connectors are available, with 5-pole M12 connectors. These connectors allow for a simple and fast connection between several devices.

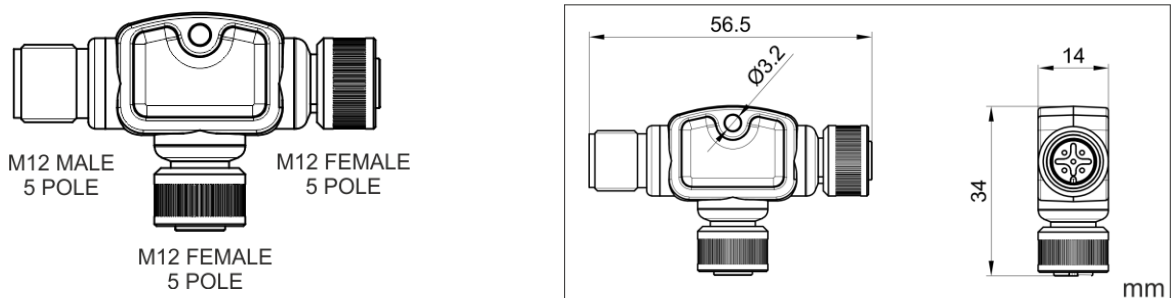

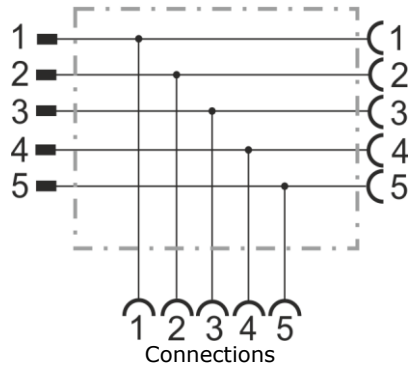

Ordering code: CONV425

### 7.4.1 T distributor for digital transmission with integrated extension cable

This model integrates the extension cable on one side. It is suitable for connection with the master unit of the Modbus network (all the measurements are in mm).

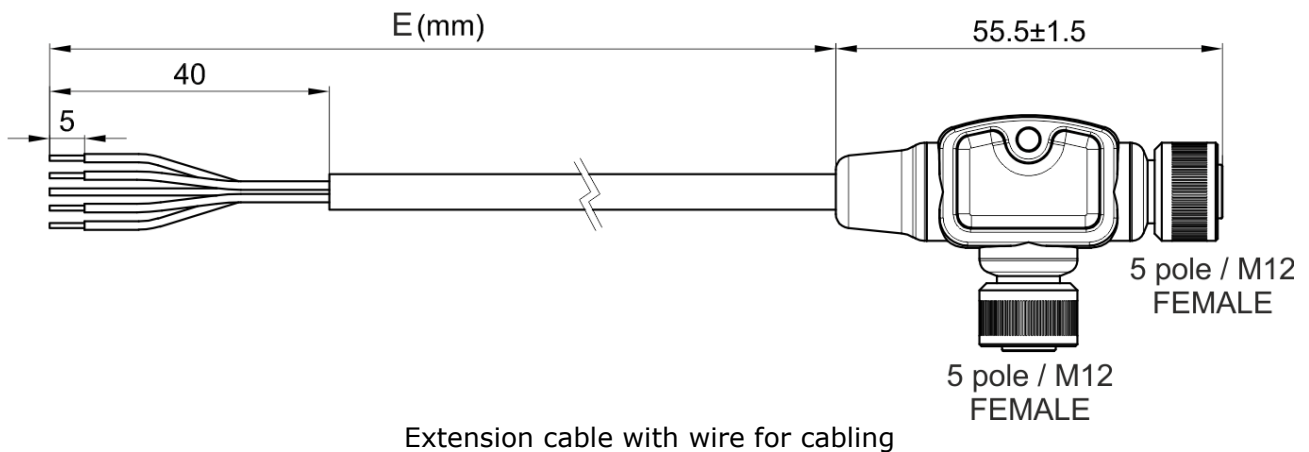
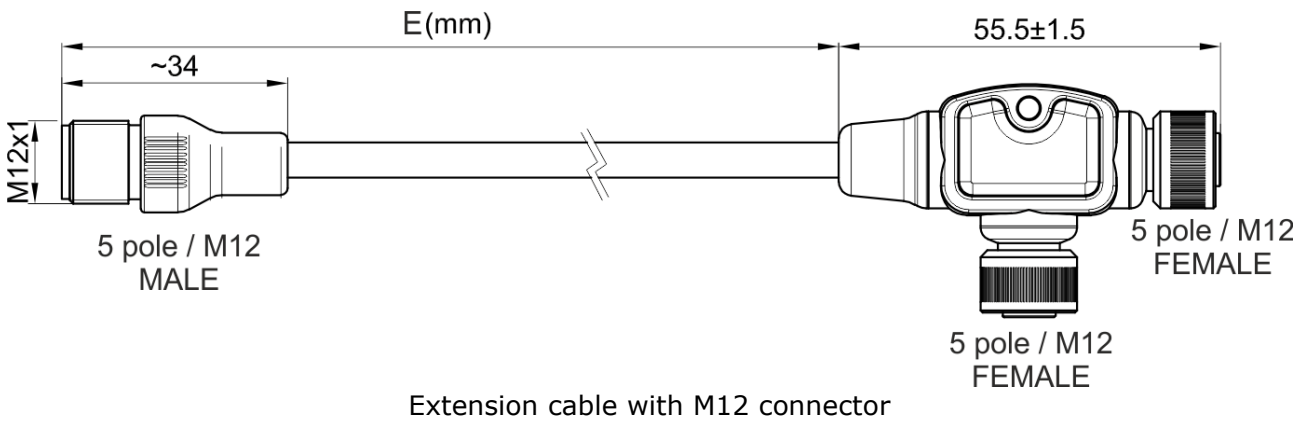



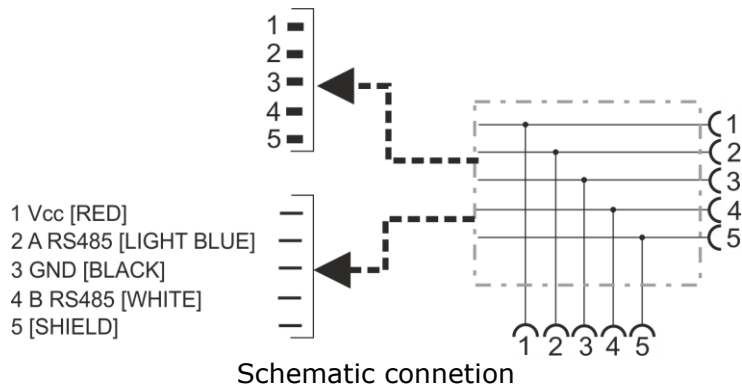

Ordering code\*:PRV#----BQSM(X)XX

\*See the technical data sheet on [products.italcoppie.it](http://products.italcoppie.it) website

### 7.5 Wall fixing bracket

The EvominiSER device, together with its probe, can be fixed to the wall with this its bracket.

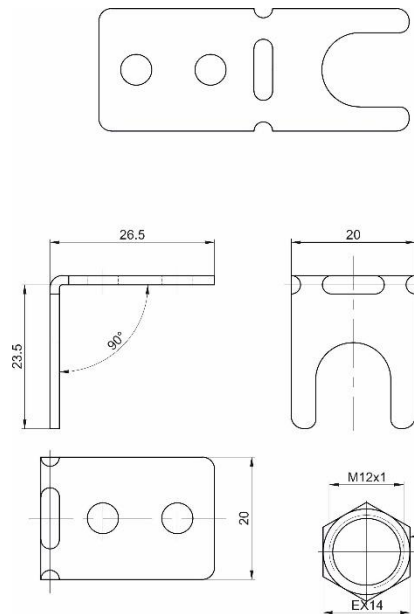

Ordering code: AMEC028.

### 7.6 Configuration kit

This kit is useful for programming Evo series devices. The Evoplatform configuring software is downloadable from the website [products.italcoppie.it](http://products.italcoppie.it)



Order code: EVOPLATFORMSET

---

## 8 Order code

### EVO032

Digital transmitter with Modbus RTU output signal (RS485 serial interface), digital input for I2C bus sensors, power supply  $(9\div 32)V_{DC}$ , IP67, operating temperature  $(40\div 80)^{\circ}C$ , M12 output male connector and M12 female input connector (Driver for RH/T sensor\*)

\* The transmitter is supplied with the communication driver for the temperature and humidity sensor (EVO033): if other compatible sensors are used, the corresponding driver must be downloaded (Refer to chapter 14)

### EVO033

Digital temperature sensor  $(-40\div 125)^{\circ}C$  and relative humidity sensor  $(0\div 100)\%$ , I2C bus interface, Sensirion SHT31 sensing element, IP67, M12 4-pole male connector, protection filter, stem (6mm diameter and 80mm length).

### EVO035

Ambient light digital sensor  $(0\div 167KLux)$ , I2Cbus interface, Vishay VEML7700-TT sensing element, M12 4 pole male connector, cable length L250mm, black plastic box

### EVO040

Digital transmitter with RS485 Modbus RTU output, input for RTD (Pt100/Pt1000), power supply  $9\div 32V_{dc}$ , IP67, M12 male connector for output, M12 female connector for input sensor

### EOSI#

Programmable Modbus RTU digital output (RS485) temperature transmitter with mineral insulated probe probe  $\varnothing \times L = xxx$  mm

### ESTP#

Programmable Modbus RTU digital output (RS485) compact temperature transmitter 1/8" GAS CIL. L=xx mm

### CONV425 / PRV#----BQSM(X)XX

Tee connector with M12 5-pole connector Male / Female-Female or Female - extension cable with Male / Female connector, or Female - extension cable with wiring / Female. 1:1 connection.

### AMEC028

Stainless steel wall fixing bracket for EvominiSER.

### EVO005

Isolator and repeater RS485 with baud rate up to 115200bps, galvanically isolated at  $200V_{AC}$ , power supply  $24V_{DC}$ .

### CAVV151

Serial cable, two AWG26 stranded copper conductors (white-blue)  $\varnothing 1.2$  ( $87\Omega$  impedance) + two Cu-Sn AWG22 stranded tinned copper conductors (red-black)  $\varnothing 1.3$  ( $64.2\Omega/km$  impedance), twisted, with Al-Mylar shielded drain wire, thermoplastic sheathed jacket PUR 90, gray  $\varnothing_{ext} 5.1 \pm 0.2mm$

### PRV#...

Extension cables with overmolded M12 5-pole male/female connectors, CAVV151 cable. Several lengths are available.

---

## EVOPLATFORMSET

Programming kit for the Evo series devices. It contains an USB interface and the connection cables (Evoplatform application downloadable from [products.italcoppie.it](https://products.italcoppie.it))

## 9. Compatible sensors

The model EvominiSER-I2C can be connected to different sensors. For each sensor, its firmware is downloadable from [products.italcoppie.it](https://products.italcoppie.it)

The correct firmware has to be installed on the converter (see chapter 14 for firmware download user guide).

These sensors are currently available:

- Temperature and relative humidity sensor (FW rel. x.xx.1)
- Surface temperature sensor (FW rel. x.xx.2)
- Luminosity sensor (FW rel. x.xx.3)

If the firmware is not compatible with the connected sensor, at power on all LEDs will be permanently on after the transmitter initialization.

The EvominiSER-RTD model can be connected with RTD sensors Pt100/Pt1000

- RTD temperature sensor (Pt100/Pt1000) (FW rel. x.xx.10)

### 9.1 Temperature and relative humidity sensor

#### Compatible firmware release:

- x.xx.1 (where x.xx can be 1.00 or newer )

#### Connection:

- Male 4-poles M12 connector, according to IEC 61076-2-101

#### Sensor stem:

- 6mm tube diameter, according to AISI 316L

#### Sensor working temperature:

- (-40÷125) °C

#### Connector operating temperature:

- (-40÷80) °C

#### Humidity sensor<sup>4</sup>:

- Hysteresis @ 25°C: ±0.8%RH
- Long-term drift: <0.25%RH/year
- Typical accuracy @25°C: ±2% (refer to Figure 7)

#### Temperature sensor<sup>4</sup>:

- Long-term drift: <0.03°C/year
- Typical accuracy: ±0.2°C from 0°C to 90°C (refer to Figure 7)

---

<sup>4</sup> For further information regarding the sensor, please refer to Sensirion SHT3x-DIS datasheet, considering the SHT31-DIS device

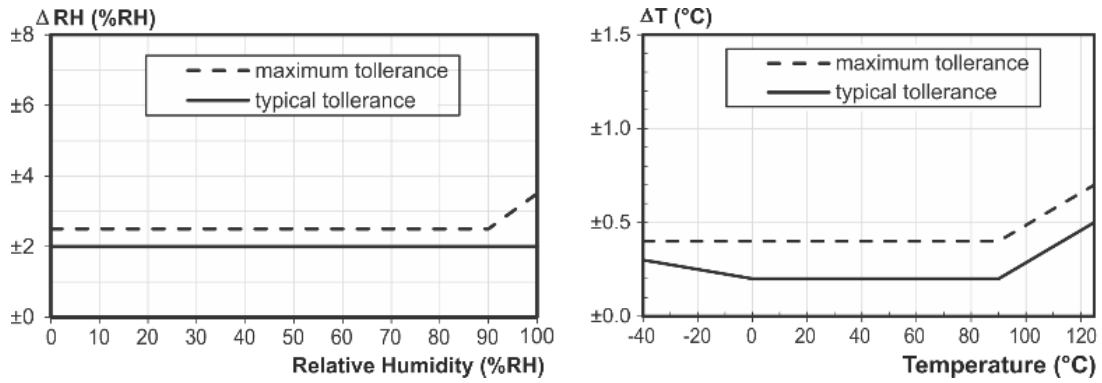

Figure 7: Sensirion SHT31 temperature and relative humidity accuracy

The temperature and relative humidity sensor mechanical dimensions are reported in Figure 8. The mechanical dimensions of the device are reported in Figure 9.

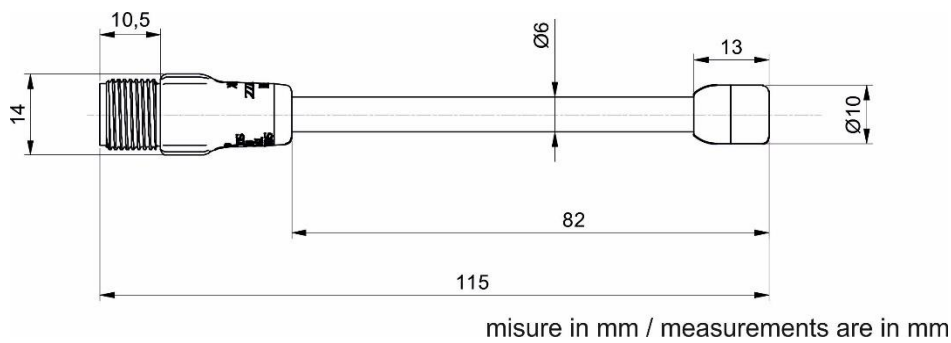

Figure 8: sensor mechanical dimension

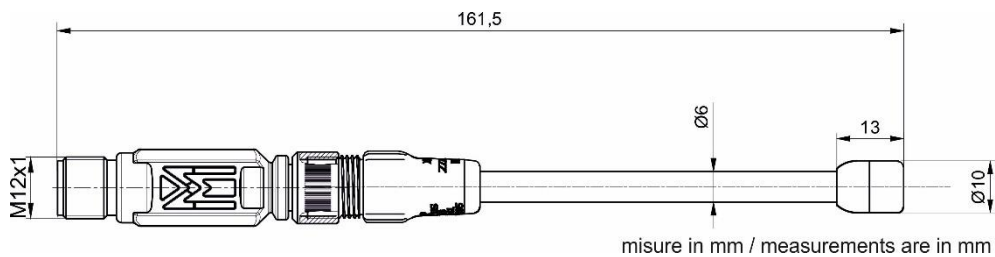

Figure 9: device mechanical dimension

## 9.2 Temperature sensor with magnetic connector

### Compatible firmware release:

- x.xx.2 (where x.xx can be 1.00 or newer)

### Connection:

- Male 4-poles M12 connector, according to IEC 61076-2-101

### Sensor stem:

- Acciaio AISI 316L

### Sensor working temperature:

- $(-20 \div 85)$  °C

### Temperature sensor<sup>5</sup>:

- Long-term drift:  $<0.03^{\circ}\text{C}/\text{year}$
- Typical accuracy:  $\pm 0.2^{\circ}\text{C}$  from  $0^{\circ}\text{C}$  to  $90^{\circ}\text{C}$  (refer to Figure 10)

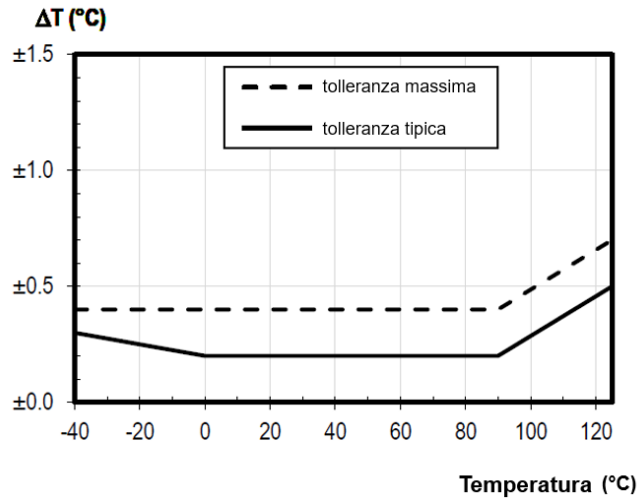

Figure 10: Sensirion STS31 temperature accuracy

The temperature sensor mechanical dimensions are reported in Figure 11.

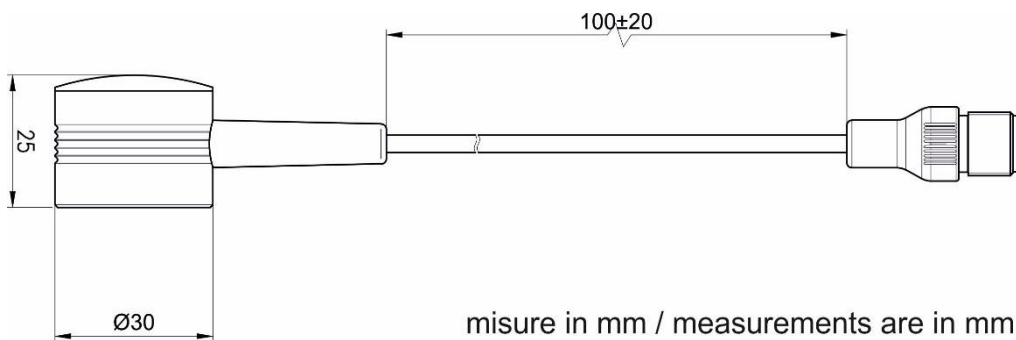

Figure 11: Sensor mechanical dimensions

## 9.3 Sensor for ambient light

### Compatible firmware release:

- x.xx.3 (where x.xx can be 1.00 or newer)

### Connection:

- 4 Pole M12 male connector (according to IEC 61076-2-101)

### Sensor body:

- ABS black

### Sensor working temperature:

- $(-25 \div 80)^{\circ}\text{C}$

<sup>5</sup> For further information regarding temperature sensor, please refer to STS3x-DIS datasheet

**Lux sensor specifications<sup>6</sup>:**

- Digital sensor model Vishay VEML7700-TT
- Range: 0÷120KLux
- Typical accuracy: see Figure 12
- Temperature compensated
- Sensitivity spectrum close to human eye photopic curve  $V(\lambda)$  (see Figure 13)

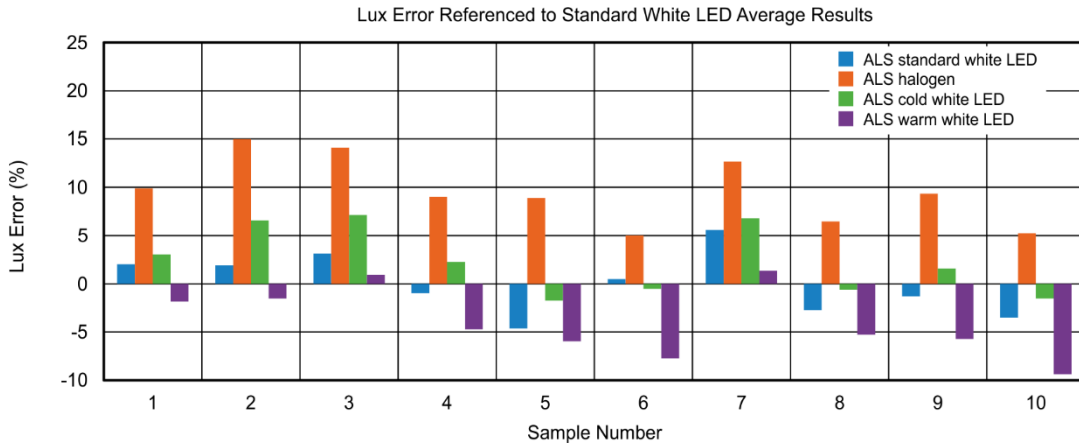

Figure 12: Sensor accuracy

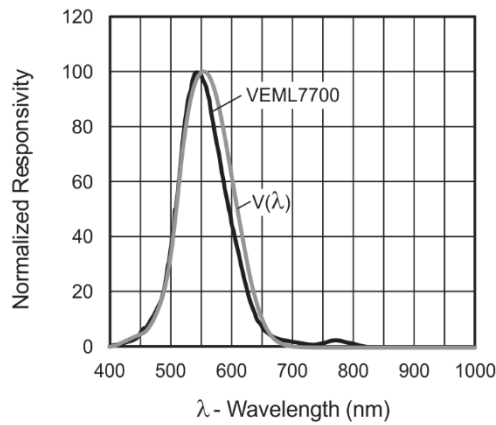

Figure 13: Spectral response

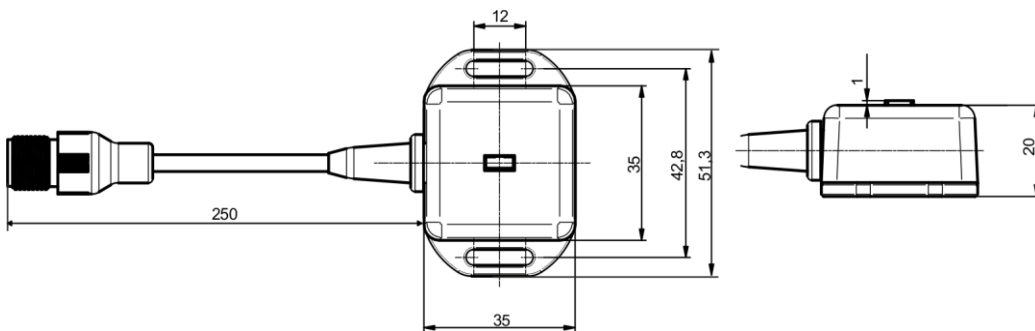

Figure 14: mechanical dimensions

<sup>6</sup> For further information regarding temperature sensor, please refer to Vishay VEML7700-TT datasheet

## 9.4 RTD temperature sensor

### Compatible firmware release:

- x.xx.10 (where x.xx can be 1.00 or newer)

For the technical characteristics refer to chapter 5

## 10. Modbus registers table

In this chapter, the implemented registers and coils are reported. While process data change depending on the supported sensors, the other registers are device independent. Some of these register values are stored in the device non-volatile memory, in order to maintain the value when device is turned off. For these registers, the column E<sup>2</sup>P is marked in the following tables. Some of the implemented registers are readable and writable while some others are only-readable. Between writable registers, there are some in which the effect of the new inserted value is immediate while others in which a device reset is necessary to enable the new inserted value. In the following tables, the range of acceptable values for each register has been specified.

### 10.1 Modbus communication parameters

Modbus address	Register name	Range	Notes	E <sup>2</sup> P
40051	Modbus address*	1 ÷ 247	Read/Write	X
40052	Baud Rate Modbus*	2 ÷ 4 2 => 9600bps 3 => 19200bps 4 => 38400bps	Read/Write	X
40053	Modbus parity*	0 ÷ 2 0 => no parity bit 1 => even parity bit 2 => odd parity bit	Read/Write	X
40054	Data bit number*	0 0 => 8 bit per data	Read/Write	X
40055	Stop Bits number*	0 ÷ 1 0 => 1 stop bit 1 => 2 stop bit	Read/Write	X
40056	Modbus delay time**	0 ÷ 255 (2ms resolution)	Read/Write	X

\* The effect of parameter's modification is valid only after device reset.

For example, if you change the Modbus address from 1 to 2, the device will continue to respond to address 1 as long as it is powered on: when it is powered back on, it will respond to address 2.

\*\* The effect of parameter's modification is immediate.

**WARNING:** It is recommended not to change the communication parameters when the devices are connected to the network.

**NOTE:** In the next paragraphs, the read-only parameters will be indicated with [R] and the reading and writing parameters with [R / W].

---

### 10.1.1 Modbus communication parameters description

#### **Address 40051: Modbus address[R/W]**

*Default value:1 Range: 1÷247*

This parameter is the specific identification of the device inside the network. This value is saved into non-volatile memory and, in order for its modification to have effect, the device should be restarted.

*Warning: the Modbus network cannot have two devices sharing the same address. Otherwise, there will be a communication conflict.*

#### **Address 40052: Baud rate[R/W]**

*Default value:2 (9600 bps); Range: 2÷4*

This parameter specifies the set data rate, expressed in bit/s. This value is saved into non-volatile memory and, in order for its modification to have effect, the device should be restarted.

Admissible values: 2 corresponds to 9600bps, 3 to 19200bps, 4 to 38400bps.

*Warning: all devices on Modbus network must share the same baud rate.*

#### **Address 40053: Parity[R/W]**

*Default value:0 (none); Range: 0÷2*

This parameter specifies if a parity bit has been set, and which parity option has been chosen. This value is saved into non-volatile memory and, in order for its modification to have effect, the device should be restarted.

Admissible values: 0 corresponds to no parity bit selected, 1 corresponds to an even parity bit, 2 to an odd parity bit.

*Warning: all devices on Modbus network must share the same parity setting.*

#### **Address 40054: Number of data bits[R/W]**

*Default value:0 (8 data bit)*

This parameter specifies the serial communication's data bit number. The only available option is 8-bit data. This value is saved into non-volatile memory.

#### **Address 40055: Number of stop bits[R/W]**

*Default value:0 (1 Stop bit); Range: 0÷1*

This parameter specifies the number of stop bits added to the frame. This value is saved into non-volatile memory and, in order for its modification to have effect, the device should be turned off.

Admissible values: 0 corresponds to one stop bit, 1 corresponds to two stop bits.

#### **Address 40056: Delay time Rx-Tx[R/W]**

*Default value:0 (0 ms) Range: 0÷255*

This value identifies the delay added between query reception and its response transmission. Each unit represents a delay of 2ms. Writing this parameter takes effect immediately.

For example:

0x0000 = 0 ms

0x0001 = 2 ms

...

0x00FF = 255x2 = 0.51 s.



## 10.2 Device parameters

Modbus address	Register name	Range	Notes	E <sup>2</sup> P
40061	Device name (first part)	2 ASCII characters	Read/Write*	X
40062	Device name (second part)	2 ASCII characters	Read/Write*	X
40063	Watch dog time	0÷250 (500ms resolution)	Read/Write*	X
40064	Firmware release	0÷65535	Read only	**
40065	Hardware release	0÷65535	Read only	**
40066	Serial number	0÷65535	Read only	X
40067	Batch number	0÷65535	Read only	X
40068	Working time (MSW)	0÷65535 (15 min resolution)	Read only	X
40069	Working time (LSW)	0÷65535 (15 min resolution)	Read only	X
40070	System errors 0x00 – Device status OK 0x01 – Short circuit error detection 0x02 – Non-volatile memory error 0x04 – Unconnected sensor 0x08 – Measurement error 0x10 – Unknown sensor 0x20 – Firmware corrupted 0x40 – Sensor temperature over the functional limits 0x80 – Device temperature over the functional limits	--	Read only  Copy of register 40001	
40071	Device temperature minimum peak***	--	Read only	x
40072	Device temperature maximum peak***	--	Read only	X
40073	BOOT FW version	--	Read only	

\* The effect of parameter's modification is immediate.

\*\* HW and FW release are permanently defined into program memory.

\*\*\* This parameter is available only for EvominiSER-RTD item

### 10.2.1 Device parameters description

#### Addresses 40061 and 40062: Device name[R/W]

*Default value: depends on the supported sensor. For temperature and relative humidity sensor is 'EVOH', for surface temperature sensor is 'EVOT', for Lux sensor 'ELUX', for RTD sensor 'EVOA'*

32-bit ASCII char indicating transmitter name. The user can set a personal name in this register for the transmitter. This value is saved into non-volatile memory.

#### Address 40063: Watchdog time[R/W]

*Default value: 1 (0,5 seconds) Range: 0÷250*

This parameter specifies the Modbus watchdog timer value. One unit corresponds to 0.5 seconds. If the watchdog coil has been enabled and the device does not receive commands within the time set in this register, the watchdog coil event will be set.

---

This value is saved into non-volatile memory and its modification has immediate effect.

Examples:

0x0001 = 0.5 seconds

0x00FF = 127.5 seconds

**Address 40064: Firmware release[R]**

This parameter specifies the FW release

A value of 100 corresponds to a firmware version 1.00.

**Address 40065: Hardware release[R]**

This parameter specifies the HW release. A value of 10 corresponds to a hardware version 1.0.

**Address 40066: Serial number[R]**

This read-only register contains the serial number. This number is marked onto device as well. This value is saved into non-volatile memory.

**Address 40067: Batch number[R]**

This read-only register contains the batch number (week number and year of production). This number is marked onto device as well. This value is saved into non-volatile memory.

**Addresses 40068[MSW] and 40069[LSW]: Working time[R]**

This value indicates the device working time. One unit corresponds to 15 minutes. The value read at address 68 represents the least significant word while the value read at address 67 the most significant word. Therefore, the working time expressed in minutes corresponds to the value read from these two registers multiplied by 15. For example, if a value of 1 is read at address 67 and a value of 3 is read at address 68, the device is working for 16384 hours. This value is saved into non-volatile memory.

**Address 40070: System errors[R]**

This register indicates the device status. Each implemented error is assigned to a specific register bit. If the bit is cleared, the correspondent error has not been detected. On the contrary, if the bit is set, the error has been detected.

*Bit0 (0x01), Blue PWR led flashing fast*

Signals the input sensor short circuit.

Check the connection of the sensor to the converter.

*Bit1 (0x02), Red ERR led flashing*

Indicates that an error has occurred in storing the device parameters.

Try a new writing or perform the default parameters (ref. Register 40103). If the error persists, contact the dealer.

*Bit2 (0x04), blue PWR led slow flashing*

For EvominiSER-RTD it signals that the sensor is not connected.

For EvominiSER-I2C it signals that the connected sensor is not compatible with the transmitter. Check the sensor or download the correct firmware (ref. Chapter 14).

*Bit3 (0x08), blue PWR led slow flashing*

Indicates that a measurement error has occurred.

For EvominiSER-RTD it signals that the temperature is outside the set ranges (registers 40204, 40205)

For EvominiSER-I2C it signals that the processed variable is outside the functional range of the sensor.

*Bit4 (0x10) red Err, blue PWR and White Rx / Tx LEDs on steady*

Indicates that the transmitter has not recognized the sensor (this error is valid only for EvominiSER-I2C)

Check if the connected sensor is Italcoppie original.

*Bit 5 (0x20) red ERR led on steady*

Indicates that the firmware on the transmitter is corrupt.

Download the firmware again (see Chapter 14). If the error persists, contact the dealer

*Bit 6 (0x40) red ERR led flashing*

Only for EvominiSER-RTD with integrated probe. Signals that the functional limits of the device have been exceeded. Under these conditions the device could break.

*Bit 7 (0x80) red ERR led flashing*

Indicates that the internal device temperature is beyond the permitted functional limits (-40 ÷ 80 °C) (only for EvominiSER-RTD)

#### **Address 40071: Device temperature minimum peak[R]**

(Only for EvominiSER-RTD) This register stores the minimum temperature peak reached by the electronic section of the device. The device works properly up to -40°C. Values below this temperature are signaled by the flashing of the ERR LED: in these conditions, functionality is not guaranteed and the device could break.

#### **Address 40072: Device temperature maximum peak[R]**

(Only for EvominiSER-RTD) The maximum temperature peak reached by the electronic section of the device is stored in this register. The device works properly up to 80°C. Values higher than this temperature are signaled by the flashing of the ERR LED: in these conditions the functionality is not guaranteed and the device could break.

### 10.3 System parameters

Modbus address	Register name	Range	Notes	E <sup>2</sup> P
40102	Peak reset	0 ÷ 1 0 => no reset 1 => reset	Read/Write*	
40103	Default parameters	0xAAAA	Write**	
40104	Reserved address	-	-	
40105	Application FW integrity control number (MSB)	-	Read only	
40106	Application FW integrity control number (LSB)	-	Read only	

\* The effect of parameter's modification is immediate.

\*\* After device response (back to master), an automatic reset operation is executed in order to validate this command.

#### 10.3.1 System parameters description

##### **Address 40101: Reserved**

##### **Address 40102: Peak reset[W]**

*Default value:0 Range: 0÷1*

When this register is set, peaks of process data will be reset with immediate effect.

##### **Address 40103: Default values (factory parameters)[W]**

Default value:0 Admissible value: 0xAAAA (dec. 43690)

By writing the hexadecimal value AAAA to this write-only register, default factory values are set for the following parameters:

Register	Default register value	Parameter value
All the offset	0	0
Modbus address	1	1
Modbus baud rate	2	9600bps
Modbus parity	0	None
Number of data bits	0	8 bits
Number of stop bits	0	1 bit
Modbus delay	0	0ms
Device name	*	*
Watchdog time	1	0.5s
Minimum peaks	Actual value	Actual value
Maximum peaks	Actual value	Actual value
TX e RX LED status (coil)	0	ON
Configuration LED status (coil)	0	ON
Sensor type**	14	Pt100, 4W, $\alpha = 0.003850$
Ptx resistance value at 0°C**	100000	100 $\Omega$
User span Low**	200°C (EVO040) -50°C (ESTP#, EOSI#)	
User span High**	850°C (EVO040) 110°C (ESTP#) 350°C (EOSI#)	
Correction low reference**	As User Span Low	
Correction high reference**	As User Span High	
Correction low measure**	As User Span Low	
Correction high measure**	As User Span High	
One point offset correction**	0	0°C
2 wire RTD cable resistance**	0	0 $\Omega$

\* EVOH if temperature and relative humidity sensor is supported, EVOT if temperature sensor is supported, ELUX if luminosity sensor is supported, EVOA if RTD sensor is supported

\*\*Only for item EvominiSER-RTD

#### Address 40104: Reserved

Reserved addresses.

#### Addresses 40105[MSW] and 40106[LSW]: Application FW checksum[R]

In case of EvominiSER-I2C, this register contains the value of the checksum calculated and stored in the microcontroller of the device. In case of EvominiSER-RTD, this register contains the value of the CRC32 calculated and stored in the device. The value of register 40105 contains the most significant word while the value of register 40106 contains the least significant word.

## 10.4 Set sensor type

Modbus address	Register name	Range	Notes	E <sup>2</sup> P
40151	EVOSER compatibiliti	0÷1	Read only	x
40152	Sensor type	1: I2C Sensirion SHT3x 2: I2C Sensirion STS3x 3: I2C Vishay VEML7700 10: RTD EVO040 11: RTD EOSI# 12 RTS ESTP#	Read/Write	

### 10.4.1 Set sensor type description

#### Address 40151: EVOSER compatibility

It is possible to set this register only with the EvoPlatform software. If 1, the whole Modbus table is mapped as the previous EVOSER model (obsolete). This makes it possible to replace the old EVOSER model with the new EVOMINISER model in an existing plant.

Refer to EVOSER manual for modbus table.

Note: for more info refer to the EVOSER Compatibility chapter

#### Address 40152: Sensor type [R]

The type of sensor connected to the EvominiSER device is set in this register: the compatible sensors are listed in the "Range of values" column. The sensor types from 1 to 9 are digital (compatible with the EvominiSER-I2C item) while the sensor types with a value equal to or greater than 10 are RTD (compatible with the EvominiSER-RTD item).

Note: Ptx indicates that the sensor can be Pt100 or Pt1000. Register 40202 defines the Ro value of the Ptx.

## 10.5 User data (available only on EvominiSER-RTD item)

Modbus address	Register name	Range	Notes	E <sup>2</sup> P
40201	Sensor type	12: RTD Ptx 2 wire (α 3850) 13: RTD Ptx 3 wire (α 3850) 14: RTD Ptx 4 wire (α 3850) 22: Pt100 2 wire (α 3916) 23: Pt100 3 wire (α 3916) 24: Pt100 4 wire (α 3916)	Read/Write	x
40202-40203 DWORD	Ptx resistance value at 0°C (MSW) Ptx resistance value at 0°C (LSW)		Read/Write	x
40204	User span low	(-200÷850) °C	Read/Write	x
40205	User span hi	(-200÷850) °C	Read/Write	x

40206	Correction switch	(0÷3)	Read/Write	x
40207	Correction low reference	(0÷65535)	Read/Write	x
40208	Correction high reference	(0÷65535)	Read/Write	x
40209	Correction low measure	(0÷65535)	Read/Write	x
40210	Correction high measure	(0÷65535)	Read/Write	x
40211	Spare	(0÷65535)	Read/Write	x
40212	2 wire RTD cable resistance	-	-	
40213	One point offset correction	±12.5°C	Read/Write	x

### 10.5.1 User data description

User data are only available in the EvominiSER RTD and are stored in the non-volatile device memory.

#### **Address 40201: Sensor type[R]**

In this register it is possible to set the type of sensor connected to the device (only for the EVO040 model)

#### **Addresses 40202[MSW] and 40203 [LSW]: Ptx resistance, value at 0°C [R/W]**

This value is the resistance value in mΩ at 0°C ( $R_0$ ).

For ESTP# and EOSI# models with integrated sensor, this value can not be changed.

For the EVO040 model, a value between 99.000 ÷ 101.000 ohm can be set for the Pt100 and between 990.000 ÷ 1010.000 for the Pt1000.

If you use the series of sensors model TRM # set the value of  $R_0$  marked on the connector:



In the above example, register 40202 must be set at 99.95 while register 40201 (sensor type) at 14 (PTx with 4-wire connection)

Note: by setting the  $R_0$  value other than 100 or 1000Ω, the two-point error correction (register 40206=1 or 2) must be disabled (register 40206=0)

If error correction on 1 or 2 points is enabled,  $R_0$  must be set to 100 or 1000Ω (registers 40202/40203 = 100000 or 1000000)

#### **Address 40204: user span low[R/W]**

This value, in tenth of Celsius degree, indicates the allowed lower temperature measurement. The inserted value is valid only if lower than user span hi. The value is stored in non volatile data memory. Default value is according to model, i.e., the minimum temperature that can be measured.

If the temperature measured by the sensor is lower than the value set in this register, the 0x08 error is generated in the System errors (register 40070)

---

**Address 40205: user span high[R/W]**

This value, in tenth of Celsius degree, indicates the allowed higher temperature measurement. The inserted value is valid only if higher than user span lo. The value is stored in non volatile data memory. Default value is according to model, i.e., the maximum temperature that can be measured.

If the temperature measured by the sensor is lower than the value set in this register, the 0x08 error is generated in the System errors (register 40070)

**Address 40206: correction switch[R/W]**

This parameter allows you to correct the measurement error of the "transmitter + sensor" thermometric chain.

- 0: No correction
- 1,2: correction on 2 points (registers 40207 ÷ 40210)
- 3: correction on one point (register 40213)

*Note: if the correction on two points is enabled (values 1 or 2), the value of R0 must be set to the default value (registers 40202/40203 = 100000 or 1000000).*

**Address 40207: correction low reference[R/W]**

This parameter is expressed in tenths of degree and it is valid only if register 40206 is equal to 1 or 2. It identifies the lower reference temperature point on which the correction is performed. This value must be greater than or equal to the minimum measurable temperature. The default value is according to the model.

**Address 40208: correction high reference [R/W]**

This parameter is expressed in tenths of degree and it is valid only if register 40206 is equal to 1 or 2. It identifies the upper reference temperature point on which the correction is performed. This value must be less than or equal to the maximum measurable temperature. The default value is according to the model..

**Address 40209: correction low measured[R/W]**

This parameter, in tenth of degrees, defines the low measured temperature value in the correction point. Its value must be within  $\pm 10^{\circ}\text{C}$  of the correction low reference value. Default value is according to the model.

**Address 40210: correction high measured[R/W]**

This parameter, in tenth of degrees, defines the high measured temperature value in the correction point. Its value must be within  $\pm 10^{\circ}\text{C}$  of the correction high reference value. Default value is according to the model.

*Note: The EvominiSER\_RTD\_correction.xls spreadsheet is available on the website, which allows the simulation of the error correction.*

**Addresses 40211[MSW] and 40212 [LSW]: 2 wire RTD cabling resistance[R/W]**

This register is valid only if the type of sensor set is PTx with 2-wire connection; allows you to correct the reading error due to the length of the connection cable with the sensitive element. Set the value of the total resistance expressed in  $\text{m}\Omega$  (max 40,000 $\Omega$ ).

**Address 40213: one point temperature correction (temperature offset)**

This parameter is expressed in tenths of degree and is valid only if register 40206 is equal to 3. It allows you to add / subtract a temperature offset over the entire measurement range; the value must be between  $\pm 12.5^{\circ}\text{C}$ .

## 10.6 Process data



The data read from the connected sensor are called process data. Depending on the connected sensor and the installed FW, these data change.

### 10.6.1 Process data for temperature and relative humidity sensor

- Process data FW rel. x.xx.1 (temperature and relative humidity sensor)

Modbus address	Register name	Range	Notes	E <sup>2</sup> P
40001	System errors (Copy of register 40070)	--	Read only	
40002	Temperature	(-40.0÷125.0) °C	Read only	
40003	Relative humidity	(0.0-100.0) %	Read only	
40004	Dew point	--	Read only	
40005	Min. temperature peak	(-52.5÷137.5) °C**	Read only	X
40006	Max. temperature peak	(-52.5÷137.5) °C**	Read only	X
40007	Min. humidity peak	(-12.5÷112.5) %**	Read only	X
40008	Max. humidity peak	(-12.5÷112.5) %**	Read only	X
40009	Temperature offset	(-12.5÷12.5) °C	Read/Write*	X
40010	Humidity offset	(-12.5÷12.5) %	Read/Write*	X

\* The effect of parameter's modification is immediate.

\*\* Values that are outside measurement range are only due to the offset setup.

### 10.6.2 Process data for temperature and relative humidity sensor description

#### Address 40001: System errors[R]

This register is a copy of 40070

#### Address 40002: Temperature[R]

Detected temperature values, expressed in tenths of Celsius degree. For example, a value of 100 corresponds to a temperature of 10.0°C. The measurement range is (-40÷125)°C.

#### Address 40003: Relative humidity[R]

Detected relative humidity, expressed in tenths of percentage. For example, a value of 100 corresponds to 10.0%RH. The measurement range is (0÷100)%.

#### Address 40004: dew point[R]

Dew point calculated value expressed in tenths of Celsius degree. For example, a value of 100 corresponds to a dew point temperature of 10.0°C.

NOTE: this value is update only when no measurement error is detected and when the sensor is connected.

#### Address 40005: Temperature min. peak [R]

Temperature minimum detected peak, expressed in tenths of Celsius degree. This value is stored into device non-volatile memory. Therefore, this value is permanently stored. To reset this value, a specific action should be taken (acting on address 40102).

#### Address 40006: Temperature max. peak [R]

Temperature maximum detected peak, expressed in tenths of Celsius degree. This value is stored into device non-volatile memory. Therefore, this value is permanently stored. To reset this value, a specific action should be taken (acting on address 40102).



**Address 40007: Relative humidity min. peak [R]**

Relative humidity minimum detected peak, expressed in tenths of percentage. This value is stored into device non-volatile memory. Therefore, this value is permanently stored. To reset this value, a specific action should be taken (acting on address 40102).

**Address 40008: Relative humidity max. peak[R]**

Relative humidity maximum detected peak, expressed in tenths of percentage. This value is stored into device non-volatile memory. Therefore, this value is permanently stored. To reset this value, a specific action should be taken (acting on address 40102).

**Address 40009: Temperature offset[R/W]**

*Default value:0.0°C; Range: ±12.5°C*

This value, expressed in tenths of Celsius degree, adds a positive/negative offset to the sensor measured temperature.

For example, a +100 value of the offset adds +10.0°C to the measured temperature. If the value of 255 is the measured temperature, the value read in register 0 will be 355 corresponding to 35.5°C.

**Address 40010: Relative humidity offset[R/W]**

*Default value:0.0%; Range: ±12.5%*

This value, expressed in tenths of percentage, adds a positive/negative offset to the sensor measured relative humidity.

For example, a -100 value of the offset subtracts -10.0% to the measured relative humidity. If the value of 505 is the measured relative humidity, the read value in register 1 will be 405 corresponding to 40.5%RH.

### 10.6.3 Process data for surface temperature sensor

- Process data FW rel. x.xx.2 (temperature sensor)

Modbus address	Register name	Range	Notes	E <sup>2</sup> P
40001	System errors (Copy of register 40070)	--	Read only	
40002	Temperature	(-40.0÷125.0) °C	Read only	
40003	Min. temperature peak	(-52.5÷137.5) °C**	Read only	X
40004	Max. temperature peak	(-52.5÷137.5) °C**	Read only	X
40005	Temperature offset	(-12.5÷12.5) °C	Read/Write*	X

\* The effect of parameter's modification is immediate.

\*\* Values that are outside measurement range are only due to the offset setup.

### 10.6.4 Process data for surface temperature sensor description

**Address 40001: System errors[R]**

This register is a copy of 40070

**Address 40002: Temperature[R]**

Detected temperature values, expressed in tenths of Celsius degree. For example, a value of 100 corresponds to a temperature of 10.0°C. The measurement range is (-40÷125)°C.

### Address 40003: Temperature min. peak [R]

Temperature minimum detected peak, expressed in tenths of Celsius degree. This value is stored into device non-volatile memory. Therefore, this value is permanently stored. To reset this value, a specific action should be taken (acting on address 40102).

### Address 40004: Temperature max. peak [R]

Temperature maximum detected peak, expressed in tenths of Celsius degree. This value is stored into device non-volatile memory. Therefore, this value is permanently stored. To reset this value, a specific action should be taken (acting on address 40102).

### Address 40005: Temperature offset[R/W]

Default value:0.0°C; Range: ±12.5°C

This value, expressed in tenths of Celsius degree, adds a positive/negative offset to the sensor measured temperature.

For example, a +100 value of the offset adds +10.0°C to the measured temperature. If the value of 255 is the measured temperature, the value read in register 0 will be 355 corresponding to 35.5°C.

## 10.6.5 Process data for Lux sensor

- Process data for FW vers. x.xx.3 (Lux sensor)

Modbus address	Register name	Range	Notes	E <sup>2</sup> P
40001	System errors (Copy of register 40070)	--	Read only	
40002	Lux value [MSW] Lux value [LSW]	0÷120000.00 Lux	Read only	
40004	Min. Lux Peak [MSW] Min. Lux Peak [LSW]	-500.00÷120500.00 Lux**	Read only	X
40006	Max Lux Peak [MSW] Max Lux Peak [LSW]	-500.00÷120500.00 Lux**	Read only	X
40008	Lux offset [MSW] Lux offset [LSW]	-500.00÷500.00 Lux	Read/Write*	

\* The effect of parameter's modification is immediate.

\*\* Values that are outside measurement range are only due to the offset setup.

## 10.6.6 Process data for Lux sensor description

### Address 40001: System errors[R]

This register is a copy of 40070

*Warning: each variable below mentioned is two 16-bit registers. The first register is always the most significant word (MSW)*

### Address 40002-40003: Luminosity[R]

Detected luminosity values, expressed in cents of Lux. For example, a value of 1000 corresponds to a luminosity 10.00 Lux. The measurement range is (0÷120000.00) Lux.

### Address 40004-40005: Minimum luminosity peak[R]

Luminosity minimum detected peak, expressed in cents of Lux. This value is stored into device non-volatile memory. Therefore, this value is permanently stored.

To reset this value, a specific action should be taken (acting on address 40102).

### Address 40006-40007: Maximum luminosity peak [R]

Luminosity maximum detected peak, expressed in cents of Lux. This value is stored into device non-volatile memory. Therefore, this value is permanently stored.  
To reset this value, a specific action should be taken (acting on address 40102).

### Address 40008-40009: Luminosity Offset [R/W]

Default value: 0.00Lux; Range:  $\pm 500.00^{\circ}\text{C}$

This value, expressed in cents of Lux, adds a positive/negative offset to the sensor measured luminosity.

For example, a +1000 value of the offset adds +10.00Lux to the measured luminosity. If the value of 120.00 is the measured Luminosity, the value read in register 0 will be 13000 corresponding to 130.00 Lux.

Note: This double register must be written using the multiple write command (function code 16). Writing of the single register (function code 6) is not accepted.

## 10.6.7 RTD temperature sensor process data

- Process data for FW rel. x.xx.10 (RTD temperature sensor)

Indirizzo Modbus	Nome parametro	Intervallo valori	Note	E <sup>2</sup> P
40001	System errors (Copy of register 40070)	--	Read only	
40002	Temperature	(-200.0÷850.0) °C	Read only	
40003	Resistance MSW	--	Read only	
40004	Resistance LSW	--	Read only	
40005	min. Temperature peak	--	Read only	X
40006	max. Temperature peak	--	Read only	X
40007	Reserved	--	Read only	X
40008	Reserved	--	Read only	X
40009	Reserved	--	Read only	X
40010	Reserved	--	Read only	X

## 10.6.8 RTD temperature sensor process data description

### Address 40001: System errors[R]

This register is a copy of 40070

### Address 40002: Temperature[R]

Measured temperature, in tenth of Celsius degrees. For example, a value of 100 corresponds to 10.0°C. Measurement range is defined by span low and span high (registers 40204 and 40205).

### Addresses 40003 and 40004: Resistance[R]

Input measured resistance, in mΩ.

### Address 40005: Minimum temperature peak[R]

Minimum detected temperature peak. This value is stored in the non volatile memory. Therefore, it is permanently stored in the device even after a power off. To reset this value, see 40102 register.

### Address 40006: Maximum temperature peak[R]

Maximum detected temperature peak. This value is stored in the non volatile memory. Therefore, it is permanently stored in the device even after a power off. To reset this value, see 40102 register.

#### 10.6.9 Fast start of device at power-on

Only using the EvoPlatform software is it possible to enable the "Fast start" at power-on option. If enabled, the device does not perform the initial wait cycle of about 5 seconds (blinking of the blue LED) but makes the data available on the modbus network after about 700 / 800mS from power on.

To enable fast start, you need to read the device with EvoPlatform then in the "Communication" TAB click on the "Activate" button

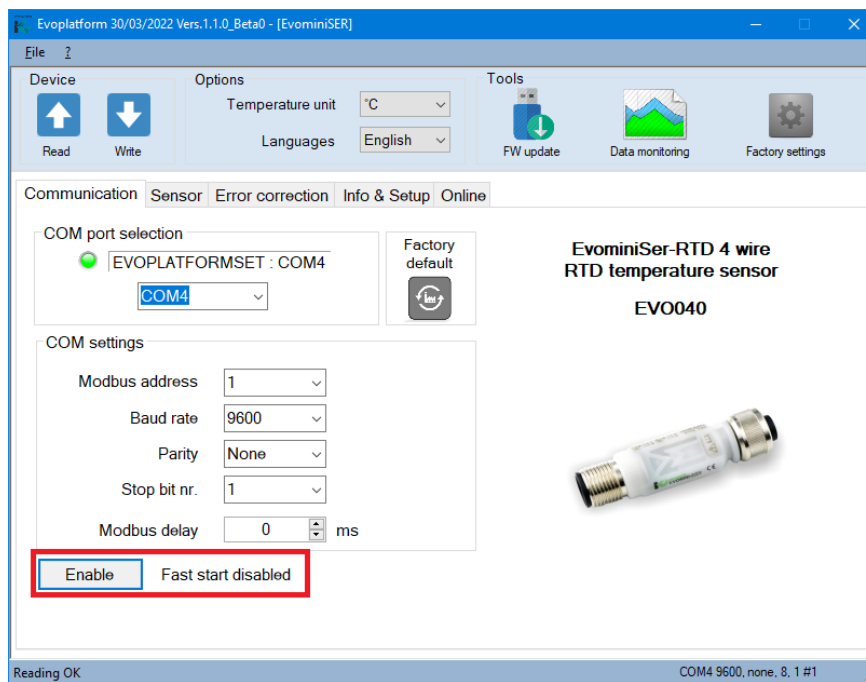

By pressing the Enable key, "Fast start enabled" will appear:

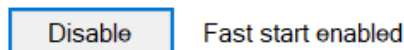

It is possible Enable/Disable this function anytime

## 11. Modbus coils table

Modbus address	Register name	Range	Notes	E <sup>2</sup> P
00001	Watch Dog event enable	ON/OFF	Read/Write*	
00002	Watch Dog event	ON/OFF	Read/Write*	
00003	Power Up event	ON/OFF	Read/Write*	
00004	TX and RX LEDs status	ON/OFF	Read/Write*	X
00005	PWR LED status	ON/OFF	Read/Write*	X

\* The effect of parameter's modification is immediate.

---

## 11.1 Coil description

All the following coils are found at zero address.

### **Address 00001: Watchdog enable**

*Default value: OFF (Disabled watchdog)*

Set this coil to enable Modbus watchdog.

Warning: this coil is not stored in the permanent memory of the device. If it is set to ON the next time it is switched on, it will return to OFF (Default value)

### **Address 00002: Watchdog event**

If coil 0 has been activated, a set value indicates that the device has not received commands within the set watchdog time value (register 40063). This coil can be cleared to reset the event. If the coil is forced high, a watchdog event is simulated together with its alarm condition.

1 = Alarm

0 = No event

For example, this coil can be used by the SCADA software to monitor the communication.

### **Address 00003: Power-UP event**

This coil is set after power-on event. It must be manually cleared to monitor a reset event.

1 = Reset

0 = No reset

### **Address 00004: Transmission and reception LED status[R/W]**

*Default value: OFF (LED OFF)*

Clear this register for these LEDs activation; set this register to deactivate these LEDs. This value is saved into non-volatile memory.

### **Address 00005: PWR LED status[R/W]**

*Default value: OFF (LED OFF)*

Clear this register for this LED activation; set this register to deactivate this LED. This value is saved into non-volatile memory.

*Attention: if both coils 4 and 5 are set, it would be possible to save energy. This can be particularly useful at power on, when several devices are connected and the current supplied is limited.*

---

## 12 Modbus RTU

### 12.1 Introduction to Modbus protocol

Modbus is a serial communication protocol originally published by Modicon (Schneider Electric) in 1979 for use with its PLCs. It has become a widespread communication protocol, commonly used in industrial electronic device interconnections. When the specifications became public and open, the Modbus protocol was adopted in numerous automation applications and subsequently in all sectors.

For many years it has been a *de facto* standard, and the Modbus protocol can be found on any "intelligent" equipment (IFD - Intelligent Field Device): programmable controllers, NC, drivers, man/machine terminals, measurement equipment, etc.

### 12.2 Master-slave protocol model

The connection is made over an RS-485 multipoint network, typically by means of a twisted two-wire cable with shielding.

In the master-slave architecture, only one device (the master) can initiate transmission actions (called "queries"). The other devices (the slaves) respond by supplying the requested data to the master, or by taking the action requested in the query. The master can address individual slaves, or can initiate a broadcast messages to all the slaves. Slaves return a message (called a "response") to queries that are addressed to them individually. Response messages are not returned to broadcast queries from the master.

The EvominiSER implements a master-slave, multipoint, half-duplex communication system, in which only the Master (typically a Host PC) can initiate communications with a request ("Query"), while the Slaves respond with a message ("Response") only to the queries addressed directly to themselves. The Modbus protocol establishes the format for the master's query by placing into it the device (or broadcast) address, a function code defining the requested action, any data to be sent, and an error-checking field. The slave's response message is also constructed using Modbus protocol. It contains fields confirming the action taken, any data to be returned, and an error-checking field.

One master can address up to 247 slaves on a single line (protocol limit). However, the RS-485 standard interface supports a maximum of 31 slaves on a single line. By replacing the last device on the RS485 line with a bridge or repeater, other 31 slaves can be added to the network. This operation can be repeated until the number of desired slaves are connected on the network (up to 247 slaves as stated before).

### 12.3 RTU transmission mode

The EvominiSER device communicates on a Modbus serial line using the RTU (remote terminal unit) mode. Each byte in a message contains two 4-bit hexadecimal characters. The main advantage of this mode is that its greater character density allows better data throughput than ASCII mode for the same baud rate. Each message must be transmitted in a continuous stream of characters. The format for each RTU mode byte is:

**Coding system:** 8 binary bits, from 00 to FF

Two hexadecimal characters are contained in each 8-bit field of the message. Each 8-bit character of the message corresponds to one data byte.

**RTU character framing:**

- 1 start bit;
- 8 data bits, least significant bit sent first;
- 1 parity bit (even or odd) or no parity bit,

1 stop bit or 2 parity bits (required in case of no parity bit).

**Address field:** valid slave device addresses are in the range of 0÷247 decimal. The individual slave devices are assigned addresses in the range of 1÷247. A master addresses a slave by placing the slave address in the address field of the message. When the slave sends its response, it places its own address in the address field of the response to let the master know which slave is responding. Address 0 is used for broadcast query (not implemented).

**Function field:** valid function field codes are in the range of 1÷255 decimal.

When a message is sent from a master to a slave device, the function code field tells the slave what kind of action to perform. When the slave responds to the master, it uses the function code field to indicate either a normal (error-free) response or that some kind of error occurred (called an exception response). For a normal response, the slave simply echoes the original function code. For an exception response, the slave returns a code that is equivalent to the original function code with its most-significant bit set to a logic 1. This tells the master what kind of error occurred, or the reason for the exception.

The EvominiSER system, implements the following Modbus functions:

<b>Modbus function code</b>	<b>Function</b>
01	Read Coil Status
02	Read Input Status
03	Read Holding Registers
04	Read Input Registers
05	Force Single coil
06	Preset Single Register
07	Read Exception Status
16	Preset Multiple Registers

In the EvominiSER system, functions 01 and 02 are identical and interchangeable, as well as functions 03 and 04.

### 12.3.1 CRC-16

The last two characters of the Modbus RTU contains a 16-bit value error checking field, implemented as two 8-bit bytes. The error check value is the result of CRC (Cyclical Redundancy Check) calculation performed on the message contents. The CRC value is calculated by the transmitting device, which appends the CRC to the message. The receiving device recalculates a CRC during receipt of the message, and compares the calculated value to the actual value it received in the CRC field. If the two values are not equal, an error has been detected. The CRC-16 algorithm is used. In order to calculate these two characters, the message (address, function code and data, excluding the start, stop and parity bit) is considered as a single binary number of which the most significant bit (MSB) is the first to be transmitted. The message is first multiplied by  $2^{16}$  (moved to the left by 16 bits) and then divided by  $2^{16} + 2^{15} + 2^2 + 1$  expressed as a binary number (110000000000101). The entire quotient is then discarded and the 16-bit remainder (initialized to FFFFh at the beginning to avoid the case of messages consisting of only zeroes) is added to the transmitted message. The resulting message, when it is divided by the receiving device in the same way ( $2^{16} + 2^{15} + 2^2 + 1$ ) will give zero as remainder if no errors have occurred (the receiving device recalculates the CRC). Since the UART unit transmits first the least significant bit (LSB) rather than the MSB, the generator polynomial is inverted. Furthermore, the MSB only influences the quotient and not the remainder. Therefore, it is deleted and the generator polynomial becomes  $2^{15} + 2^2 + 1$ . The procedure for CRC16 calculation consists of the following steps:

- 1) preload a 16-bit register to all 1's;
- 2) exclusive-OR the first character with the most significant byte of the register, and store the result into the 16-bit register;

- 3) shift the 16-bit register to the right by one bit;
- 4) if the shifted-out bit is 1, exclusive-OR the generator polynomial with the 16-bit register;
- 5) repeat steps 3) and 4) for 8 times;
- 6) exclusive-OR the next character with the most significant byte of the register, and store the result to the 16-bit register;
- 7) repeat steps 3 to 6 for the entire message;
- 8) the content of the 16-bit register is the CRC code which must be added to the message.

### 12.3.2 CRC16 flow chart

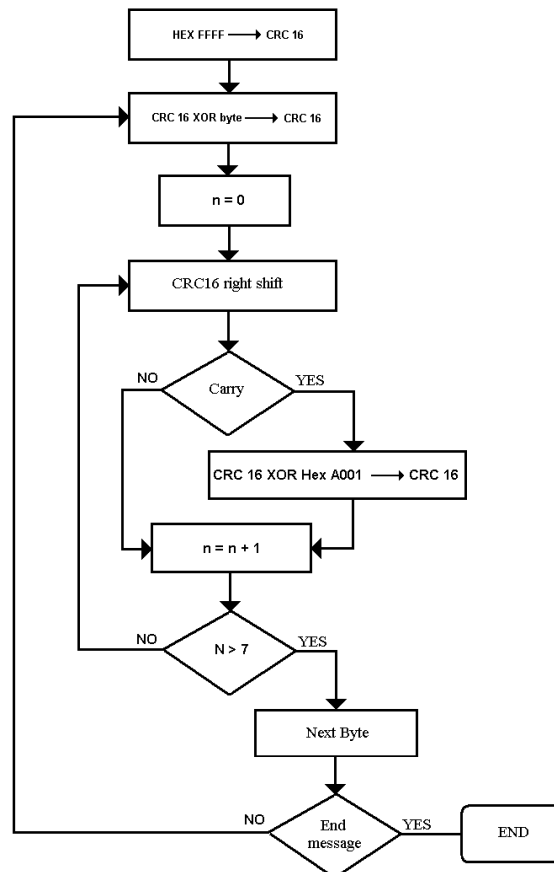

### 12.3.3 Message synchronization

In RTU mode, message frames are separated by a silent interval of at least 3.5 characters. This allows for a baud rate independent synchronization between master and slaves.

If the receiving device does not receive for a period of at least 3.5 characters, it assumes that the previous message was complete. The subsequent received information will be considered a new message. Each device on the network monitors the bus, including during the silent pauses. The first transmitted character is the address of the device. When the address has been received, each device on the network decodes it to determine to which device is addressed the message.

A silent interval of at least 3.5 characters following the message indicates its end. The entire message frame must be transmitted as continuous stream of characters. If a new message starts before the silent interval, the receiver will consider it as being a continuation of the



previous message. This will generate an error, since the value of the last field (CRC) will not be valid for the combined messages.

START	ADDRESS	FUNCTION	DATA	CRC CHECK	END
T1-T2-T3-T4	1 CHAR (8 bits)	1 CHAR (8 bits)	N CHARS (n x 8 bits)	2 CHARS (16 bits)	T1-T2-T3-T4

## 12.4 Modbus function codes

In this chapter, a detailed description of Modbus function codes implemented on EvominiSER is reported.

### 12.4.1 Read coil/input status (01 or 02)

This function allows the user to read the logical value (ON/OFF) of the bits of the addressed device. The returned data are packaged in bytes, so that the first requested bit occupies the least significant bit of the first byte of data. The others follow in such a way that if the number of bits requested is not a multiple of 8, the last byte in the response will be completed with zeroes.

Master – device frame:

Device address	Function code (01 or 02)	Address of first bit		Number of bits to read (max 255)		CRC	
		MSB	LSB	MSB	LSB	MSB	LSB
1 byte	1 byte						

Device – master frame:

Device address	Function code	Number of bytes read	First byte of data	.....	Last byte of data	CRC	
1 byte	1 byte	1 byte	1 byte	.....	1 byte	MSB	LSB

**Example:** Read 3 bits starting from the bit 0 of device addressed with 1.

Master – device frame:

Device address	Function code	Address of first bit		Number of bits to read		CRC	
01	01	00	00	00	03	7C	0B

Device – master frame:

Device address	Function code	Number of bytes read	Number of bytes of data	CRC	
01	01	01	04	50	4B

The response tells us that bits 0 and 1 (Enable Watchdog Event and Watchdog Event) are cleared while bit 2 (power-up coil) is set.

*NOTE: The response assigns zeroes to addresses which are not requested by the master; this does not mean that their real values are zero.*

### 12.4.2 Read holding/input registers (03 or 04)

This function allows the user to read the values of the registers of the addressed device.

Master – device frame:

Device address	Function code (03 or 04)	Address of register number		Number of registers to read (max 16)		CRC	
		MSB	LSB	MSB	LSB	MSB	LSB
1 byte	1 byte						

Device – master frame:

Device address	Function code	Number of bytes read	Value of first register		.....	Value of last register		CRC	
			MSB	LSB		MSB	LSB	MSB	LSB
1 byte	1 byte	1 byte			.....				

**Example:** Read 2 registers starting from register 20 (device name) of device addressed with 1.

Master – device frame:

Device address	Function code	Address of register number		Number of registers to read		CRC	
01	03	00	14	00	02	84	0F

Device – master frame:

Device address	Function code	Number of bytes read	Value of first register		Value of last register		CRC	
01	03	04	45	56	4F	55	FB	20

The response tells us that registers 20 and 21 respectively have values 4556h and 4F55h, corresponding to 'EV' 'OU' in ASCII.

Up to 16 registers can be read with one request. A request for reading more than 16 registers, generates an error frame and will be discarded.

### 12.4.3 Force single coil (05)

This function allows the user to assign the logical values (ON/OFF) of the bits of the addressed device. To deactivate a bit, two hexadecimal 0s must be sent while to activate a bit 01h or FFh must be sent. Such values must be written in the **most significant byte**.

Master – device frame:

Device address	Function code (05)	Address of bit		Value of bit		CRC	
1 byte	1 byte	MSB	LSB	MSB	LSB	MSB	LSB

Device – master frame:

Device address	Function code (05)	Address of bit		Value of bit		CRC	
		MSB	LSB	MSB	LSB	MSB	LSB
1 byte	1 byte						

**Example:** Activate bit 0 of device addressed with 1.

Master – device frame:

Device address	Function code	Address of bit		Value of bit		CRC	
		MSB	LSB	MSB	LSB	MSB	LSB
01	05	00	00	FF	00	8C	3A

Device – master frame:

Device address	Function code	Address of bit		Value of bit		CRC	
		MSB	LSB	MSB	LSB	MSB	LSB
01	05	00	00	FF	00	8C	3A

The response tells us that bit 0 (Enable Watchdog Event) has been activated.

#### 12.4.4 Preset single register (06)

This function allows the user to set a specified register of the addressed device.

Master – device frame:

Device address	Function code (06)	Address of register		Value of register		CRC	
		MSB	LSB	MSB	LSB	MSB	LSB
1 byte	1 byte						

Device – master frame:

Device address	Function code (06)	Address of register		Value of register		CRC	
		MSB	LSB	MSB	LSB	MSB	LSB
1 byte	1 byte						

**Example:** Assign 10 to register 3 to the device addressed with 1.

Master – device frame:

Device address	Function code	Address of register		Value of register		CRC	
		MSB	LSB	MSB	LSB	MSB	LSB
01	06	00	03	00	0A	F9	CD

Device – master frame:

Device address	Function code	Address of register		Value of register		CRC	
		00	03	00	0A	F9	CD
01	06						

The response tells us that register 3 (temperature bias) has been set to 10 (1.0°C).

#### 12.4.5 Preset multiple registers (16)

This function allows the user to set values for a block of consecutive 16-bit registers. No more than 16 registers can be set with a single command.

Master – device frame:

Device address	Function code (16)	First addressed register		Number of words		Number of bytes	...DATA...		CRC	
		MSB	LSB	MSB	LSB		MSB	LSB	MSB	LSB
1 byte	1 byte					1 byte				

Device – master frame:

Device address	Function code (16)	First addressed register		Number of words		CRC	
		MSB	LSB	MSB	LSB	MSB	LSB
1 byte	1 byte						

**Example:** Write two registers at the same time. Assign the value 4565h to the register 20, and 6D6Fh to the register 21 [Device name 'Demo'] to device addressed with 1.

Master – device frame:

Device addresses	Function code (16)	First addressed register		Number of words		Number of bytes	...DATA...				CRC	
		00	14	00	02		04	44	65	6D	6F	9B
01	10											

Device – master frame:

Device address	Function code (16)	First addressed register		Number of words		CRC	
		00	14	00	02	01	CC
01	10						

---

## 12.4.6 Modbus exception responses

Except for broadcast messages (not implemented in EvominiSER), when a master device sends a query to a slave device it expects a normal response. One of four possible events can occur from the master's query:

- If the slave device receives the query without a communication error, and can handle the query normally, it returns a normal response.
- If the slave does not receive the query due to communication error, no response is returned. The master program will eventually process a timeout condition for the query.
- If the slave receives the query, but detects a communication error (parity or CRC), no response is returned. The master program will eventually process a timeout condition for the query.
- If the slave receives the query without a communication error, but cannot handle it (for example, if the request is to read a non-existent coil or register), the slave will return an exception response informing the master of the nature of the error.

The exception response message has two fields that differentiate it from a normal response:

1. **Function code field:** in a normal response, the slave echoes the function code of the original query in the function code field of the response. All function codes have a most-significant bit (MSB) of 0 (their values are all below 80 hexadecimal). In an exception response, the slave sets the MSB of the function code to 1. This makes the function code value in an exception response exactly 80 hexadecimal higher than the value would be for a normal response. With the function code's MSB set, the master's application program can recognize the exception response and can examine the data field for the exception code.
2. **Data field:** in a normal response, the slave may return data or statistics in the data field (any information that was required in the query). In an exception response, the slave returns an exception code in the data field. This defines the slave condition that caused the exception.

Modbus protocol defines a list of 8 exception codes. However, EvominiSER implements only the first four of them:

<b>Error code</b>	<b>Name</b>	<b>Description</b>
01	ILLEGAL FUNCTION	Invalid function
02	ILLEGAL DATA ADDRESS	Invalid address
03	ILLEGAL DATA VALUE	Invalid data
04	SERVICE DEVICE FAILURE	An unrecoverable error occurred while the server was attempting to perform the request action

## 13 EVOSER compatibility

EVOSER is currently an obsolete product and no longer in production; however, being installed in various industrial plants, it is possible to replace it with the new EvominiSER model by adopting the following measures:

- Create an M12 adapter that swap the pins of the RS485 serial because the EVOSER pinout is different from the EvominiSER pinout:

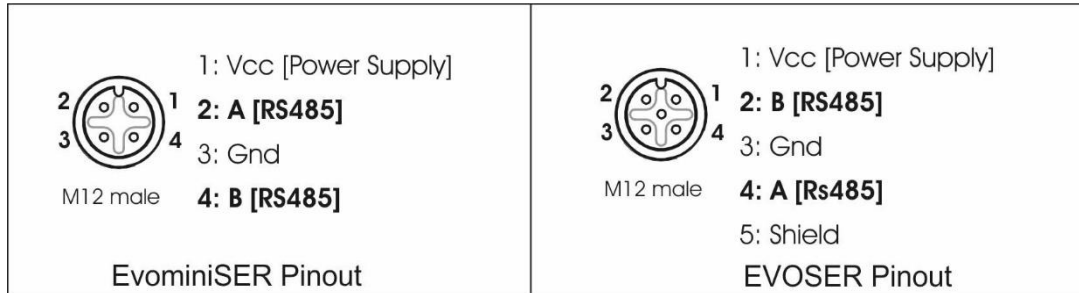

- Provide the T connector code CONV425
- EVOSER compatibility can only be enabled on the EvominiSER-I2C model equipped with the firmware for the temperature / humidity sensor

### 13.1 How to set the EVOSER compatibility

EVOSER compatibility can only be set through the EvoPlatform vers. 1.0.8 (or higher) and only from the FW version of the device 2.02.1 (or higher)

Launch EvoPlatform, click on the EvominiSER icon and read the device:

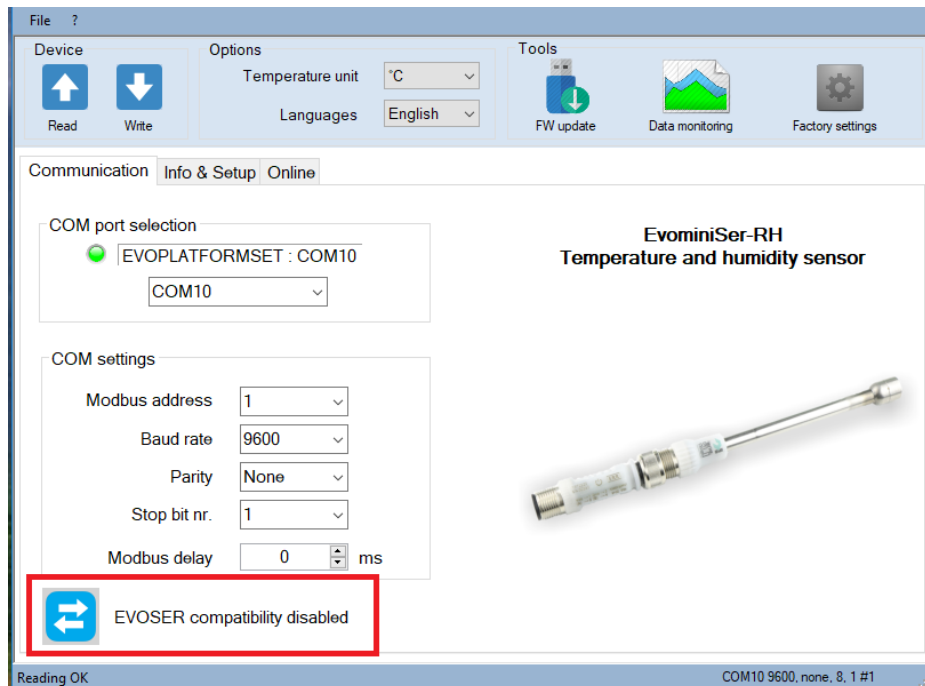

Click on the "EVOSER Compatibility" button to enable compatibility with the EVOSER device:

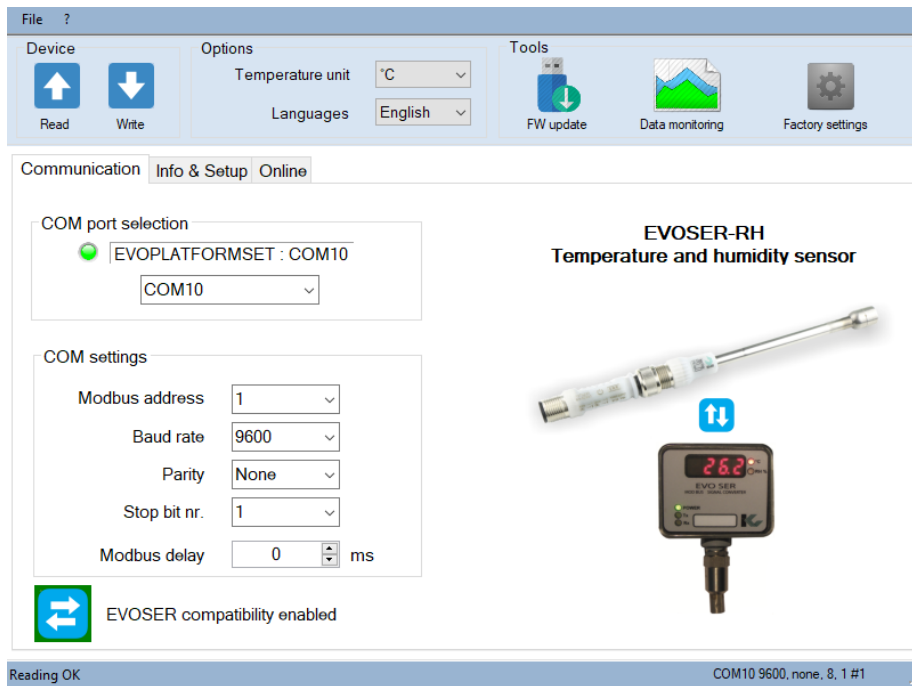

When EVOSER compatibility is enabled, the device can be installed on an EVOSER network without the need to change the software on the master unit. It is possible to enable / disable the EVOSER compatibility at any time

## 14 Device setup with EvoPlatform

The EvoPlatform software it has been developed by Italcoppie Sensori in order to configure the Evo series. The EvoPlatform is free downloadable from Italcoppie Sensori website [products.italcoppie.it](http://products.italcoppie.it).

After having properly installed the software, connect the EvominiSER to the USB port and wait for drivers to be installed.

The EvoPlatform software automatically recognizes on which COM port the interface has been installed; otherwise, from the Windows Control Panel, in "System-> Device Management-> Ports (COM and LPT) check on which COM the operating system has been assigned to the connected device.

Double-click the icon  to open EvoPlatform.



Figure 15: EvoPlatform device selection

As you can see in Figure 14, the software has recognized the kit installed on COM port 10.

*EvominiSER configuration example*

Select the EvominiSER device icon: its configuration window opens automatically, as shown in Figure 16.

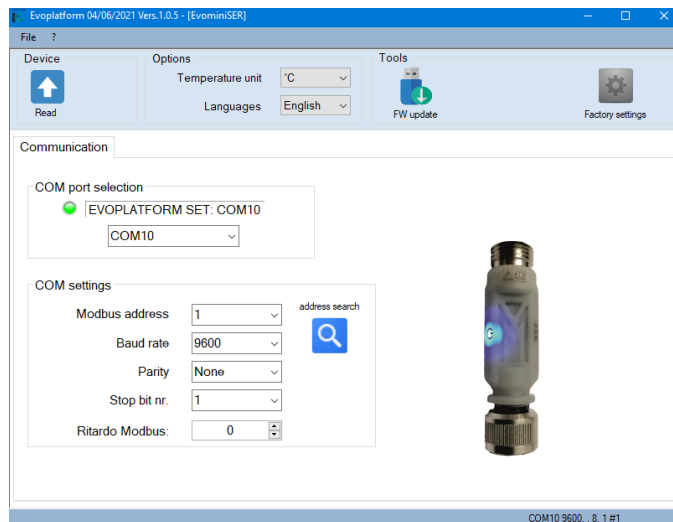

Figure 16: EvominiSER configuration window

Either if the device has not been properly connected to the USB port or the COM has not been automatically detected by the EvoPlatform, the message shown in Figure 17 is displayed. Select OK to proceed, and manually select the COM port from COM port selection menu.

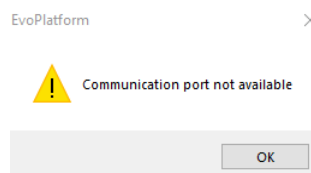

Figure 17: COM port not found

Manually select the COM number through the drop-down menu "COM port selection" (enter the COM number detected in Control Panel-> System-> Device management-> Ports (COM and LPT))



## 14.1 Configure EvominiSER

### 14.1.1 Set desired COM parameters and Modbus address

Factory settings of COM port are:

- Modbus address: 1
- Baud rate: 9600bps
- Parity: none
- Stop bit number: 1
- Modbus delay:0mS

It is possible to restore these factory settings from "Factory settings" (refer to chapter 14.1.5).

After having set COM parameters, click on "Read" to read saved configuration from connected device. If the reading operation has been successfully, the following message is displayed:

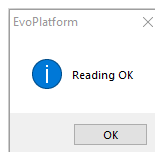

If the Modbus address is unknown, it is possible to use the "address search" function. The Modbus address is then automatically updated if device has been found.

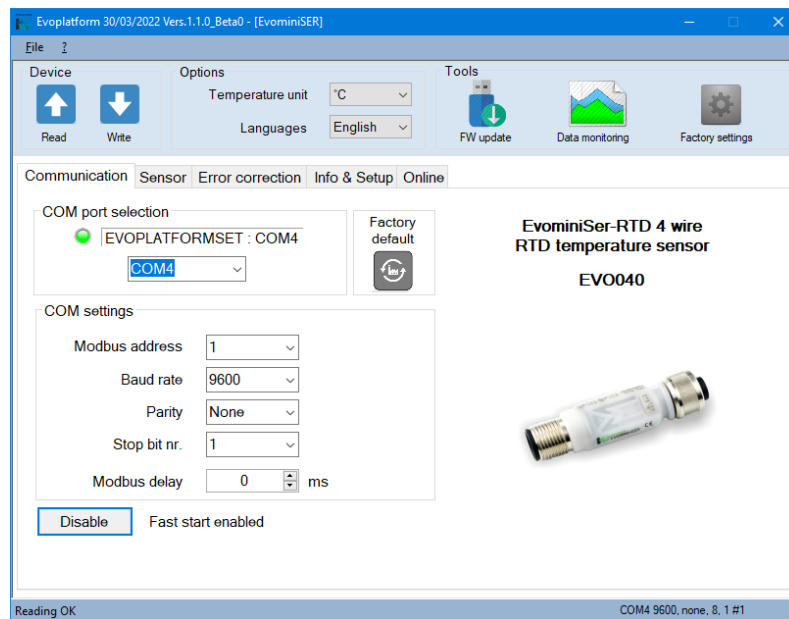

*Figure 18: device found and read*

In the "Communication" tab select the desired COM settings:

COM settings

Modbus address: 1

Baud rate: 9600

Parity: None

Stop bit nr.: 1

Modbus delay: 0 ms



To transfer these new COM parameters to the connected device, click on “Write” and wait for the following message to confirm the correct operation.

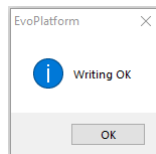

### 14.1.2 EvominiSER information and setup

The parameters of the “Info and Setup” window vary according to the model of the connected device.

Figure 18 refers to the EvominiSER-RH model. For parameters meaning and functionality, refer to chapter 10.2 (device parameters). After having set parameters to desired configuration, transfer them to the connected device by using “Write” command. The write command stores the parameters present in each window on the device.

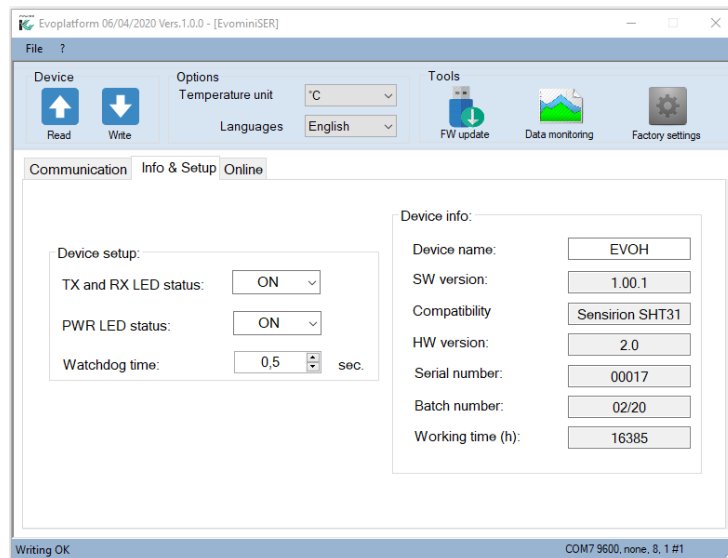

Figure 19: Info & setup menu for EvominiSER-RH

### 14.1.3 Online features

The online functions depend on the model of device connected. In particular, the process data varies depending on the sensor. For example, Figure 20 shows the example of the temperature and humidity sensor EvominiSER-RH. Starting the reading, the process parameters are displayed.

From this window it is also possible to set the watchdog and power up event coils, a temperature and relative humidity offset and delete the peaks recorded by the device using the "Reset temperature and humidity peaks" button.

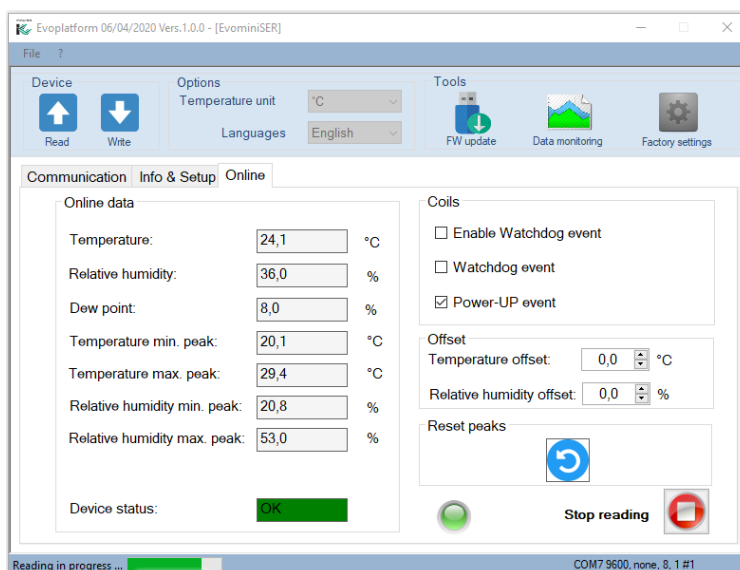

Figure 20: online menu

#### 14.1.4 Data monitoring

It is also possible to plot measured sensor variables and save them on .csv file. Click "Data monitoring" and start the operation for plotting data, as shown in Figure 21. In order to save the acquisition, just mark the "Data logging ON" option before starting the acquisition.

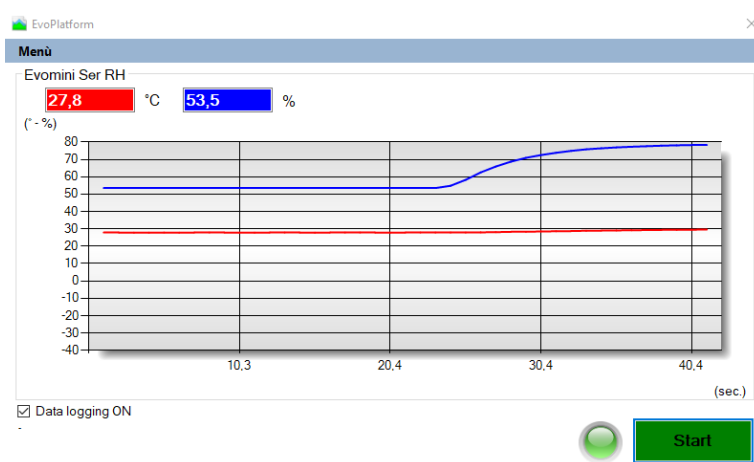

Figure 21: data monitoring<sup>7</sup>

The .csv file is placed in Documents\Italcoppie\EvoPlatform\DataEvoPlatform\EvominiSER and file is named ddmmYYYY\_h\_min\_s.csv where "dd" indicates the day, "mm" the month, "YYYY" the year, "h" the hour, "min" the minute and "s" the second at the moment of file creation.

#### 14.1.5 Factory settings

By clicking on "Factory settings",

<sup>7</sup> This image represents a temperature and relative humidity sensor

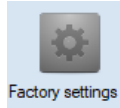

a password is required as shown below:

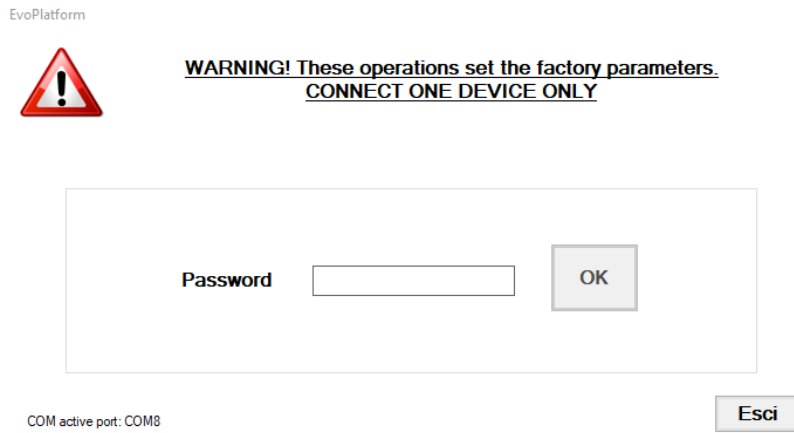

**ATTENTION:** launch factory settings command only if one device is connected to the EVOPLATFORMSET.



*If one factory setting command is executed when more devices are connected to the network, all the connected devices will be restored to factory defaults. Therefore, the network of devices will not work after the factory restore. Thus, a new setup for every single device will be necessary.*

The password **EVO#SER!** has to be inserted before pressing OK.

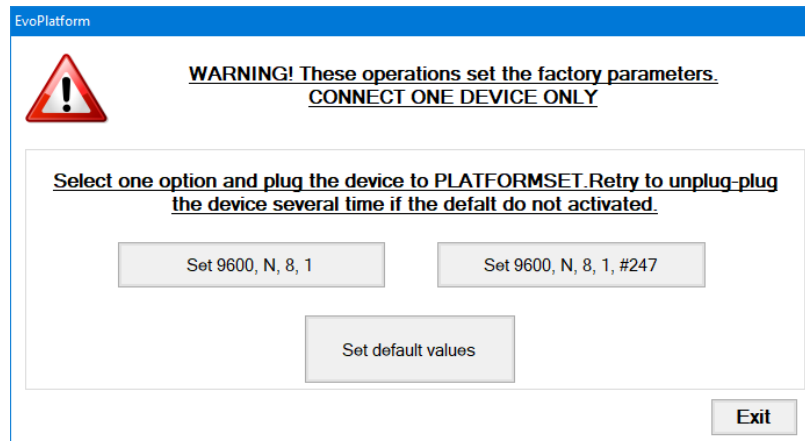

*Figure 22: factory settings menu*

Disconnect the device from the kit and click on the desired option: a flashing green LED and the "Stop default" button will appear

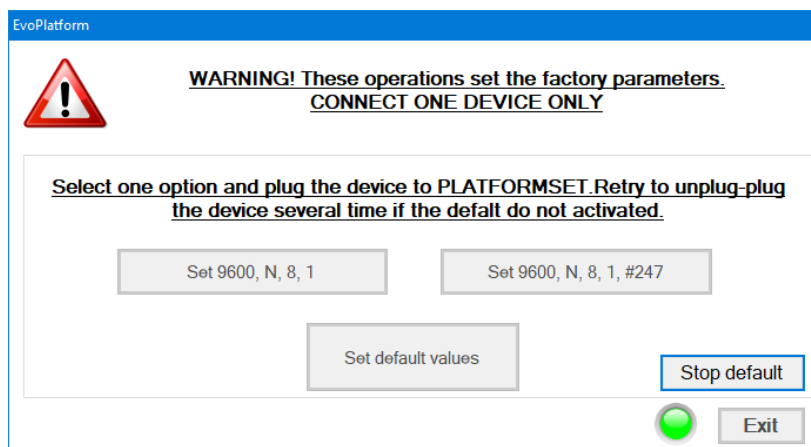

Figure 23: waiting of device

Connect the device to the EVOPLATFORMSET and wait for the confirmation message; if after a few seconds the default has not yet occurred, unplug and plug the device to the kit. It is possible to exit this procedure by clicking on the "Stop default" button and closing the window with the "Exit" button

By clicking on "Set 9600, N, 8, 1", the following COM parameters will be restored. The Modbus address of the device is not changed. Following the sending of this command, the parameters will be:

- Modbus address: unchanged;
- Baud rate: 9600bps;
- Parity: none;
- Stop bit nr.: 1;
- Modbus delay: unchanged.

The following window will be displayed.



By clicking OK, the main communication page is displayed and an automatic device search is started.

By clicking on "Set 9600, N, 8, 1, #247", the following COM parameters are set:

- Modbus address: 247;
- Baud rate: 9600bps;
- Parity: none;
- Stop bit nr.: 1;
- Modbus delay: unchanged.

The following window will be displayed.

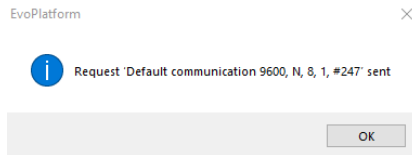

By clicking OK, the main communication page is displayed and an automatic device search is started.

By clicking on the "Set default values" button on the device the factory values are restored:

- Modbus address: 1;
- Baud rate: 9600bps;
- Parity: none;
- Stop bit nr.: 1;
- Modbus delay:0mS
- Peaks reset
- Watch dog: 0.5sec
- User Span: according to model
- Error correction:0
- 2Wire compensation (only for RTD model):0

#### 14.1.6 Configuration file

Click on menu "File-> save as" to save the configuration. The default path for the file is: "Documents \ Italcoppie \ EvoPlatform \ ConfigEvoPlatform \ EvominiSER". The default name for the file corresponds to the device serial number with .ini extension. However, it is possible to select a desired path and file name. The saved file can be opened with a text editor. In Figure 24 is reported an example of a .ini file saved for a device with serial number 100. If more devices are connected to the network, more files can be saved with different names.

```
00100.ini
1  [Starting communication parameters]
2  Modbus address=4
3  Baud rate=2
4  Parity=0
5  Stop bit nr.=0
6  [Communication parameters]
7  Modbus address=4
8  Baud rate=2
9  Parity=0
10 Stop bit nr.=0
11 Modbus delay=0
12 [Device setup]
13 Temperature Offset=0
14 Humidity Offset=0
15 LED TX & RX Status=0
16 PWR LED Status=0
17 Watchdog time=0,5
18 [Device information]
19 Name=EVOH
20 SW version=1.00.1
21 Compatibility=Sensirion SHT31
22 HW version=2.0
23 Serial number=00100
24 Batch number=20/20
25
```

Figure 24: EvominiSER configuration file

## 15 Firmware update



**IMPORTANT:** The firmware update must be done with **ONLY ONE** device connected to the EVOPLATFORMSET (it must not be done with multiple devices connected to the network)

EvoPlatform allows the user to update its EvominiSER device firmware.

By reading the device, EvoPlatform checks if the firmware is the latest version; if it is not, the following message appears:

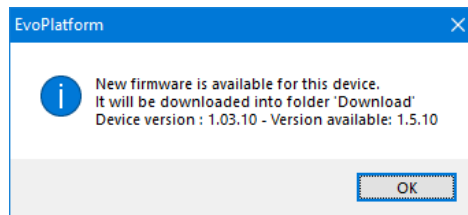

By clicking on OK, the update file (\*.evp) is downloaded to the "Download" directory of the PC.

If this file is already present in the "download" folder on the "communication" page, the message "Firmware update available" will appear:

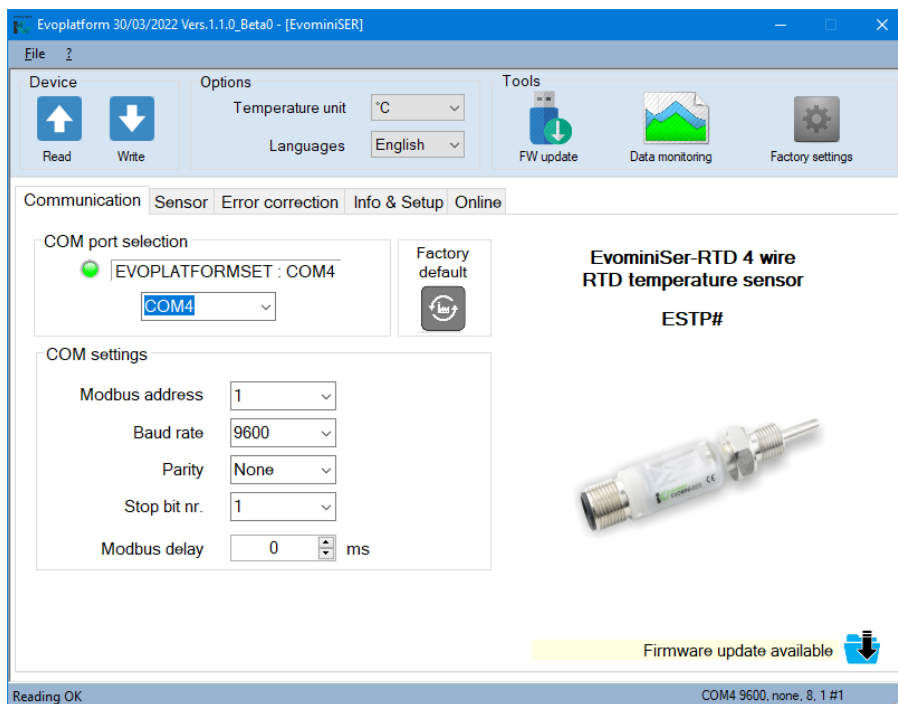

From Tools bar, click on icon FW update:



The following window will be displayed:

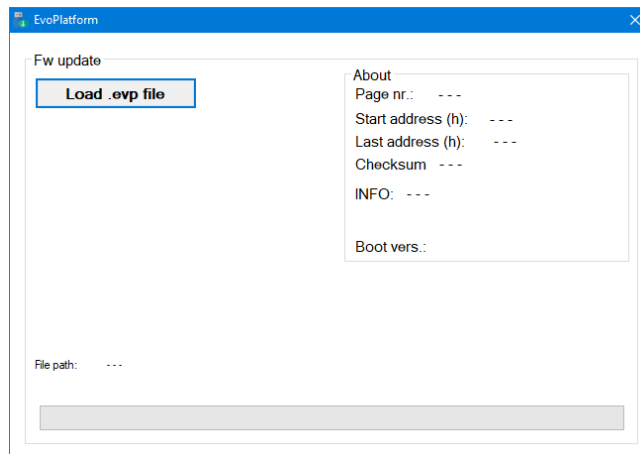

Figure 25: FW update

Click on "Load .evp file": Windows Explorer will open. Go to the download folder and double click on the \* .evp file.

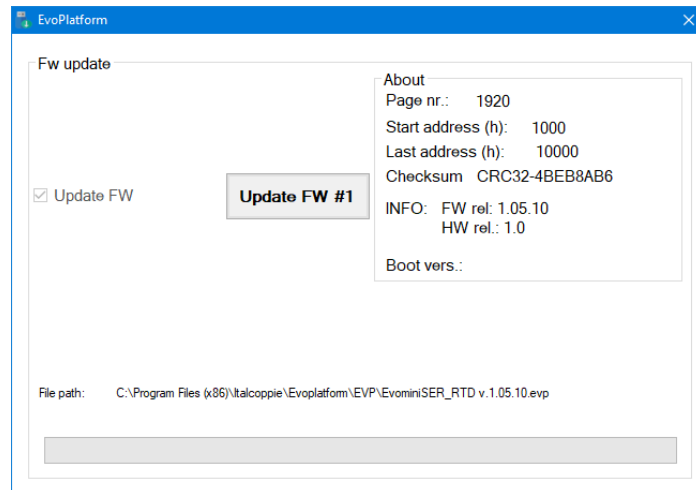
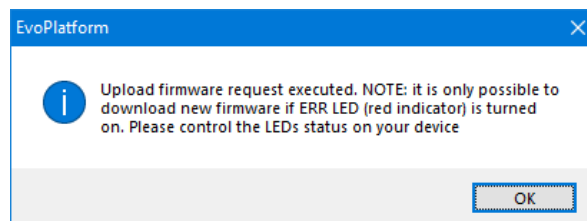
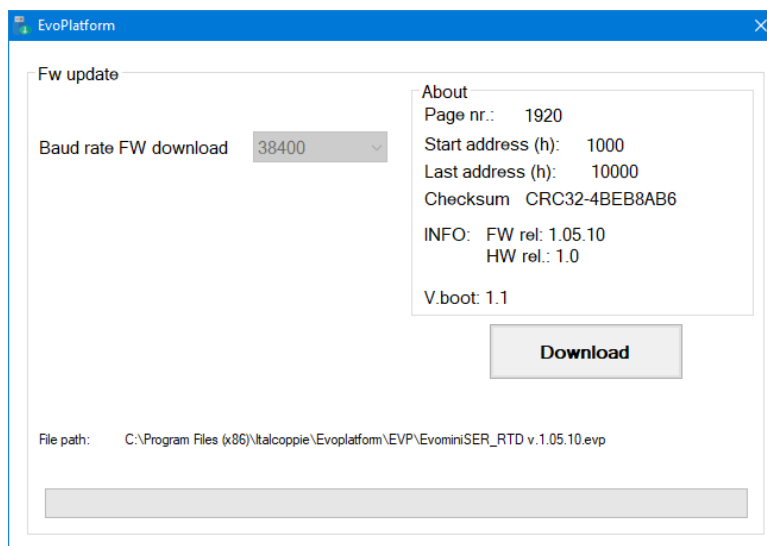

Figure 26: example of loaded .srec file

Click on "Update FW", the following window will appear and the red LED of the device will light up:







Click on "Download" and wait for the device to be updated.

### 15.1 Firmware update at the power-on device

If you do not know the communication parameters of the device, it is possible to update the firmware even without having performed a configuration reading.

Launch EvoPlatform, click on the EvominiSER icon and then on the "FW Update" icon. Click on "Upload .evp file", look for it in the PC Download folder and double click on the file. The following window will appear:

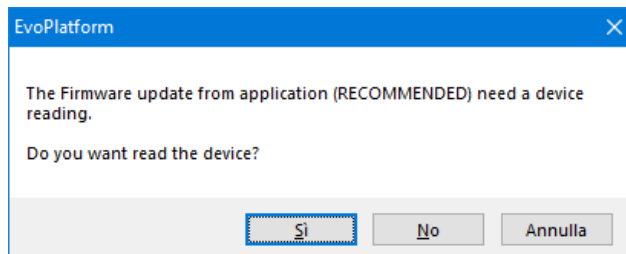

Click on "No"

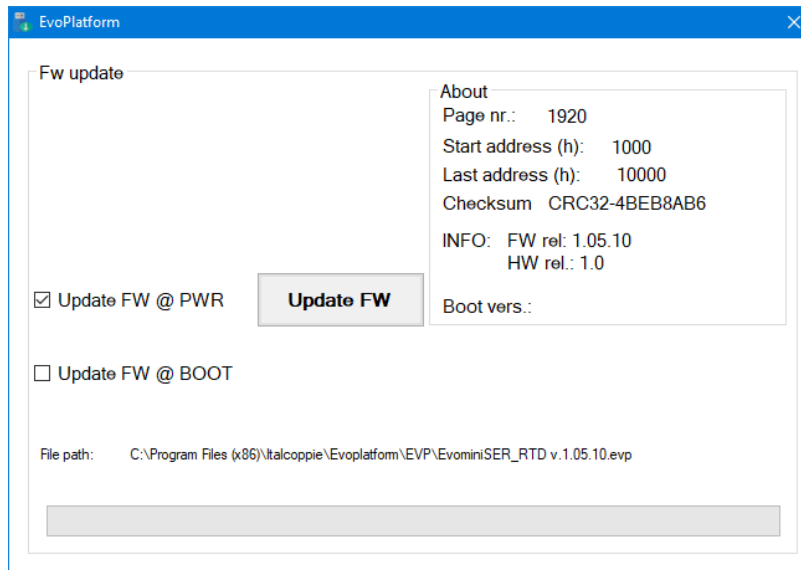

Then click on "Update FW"

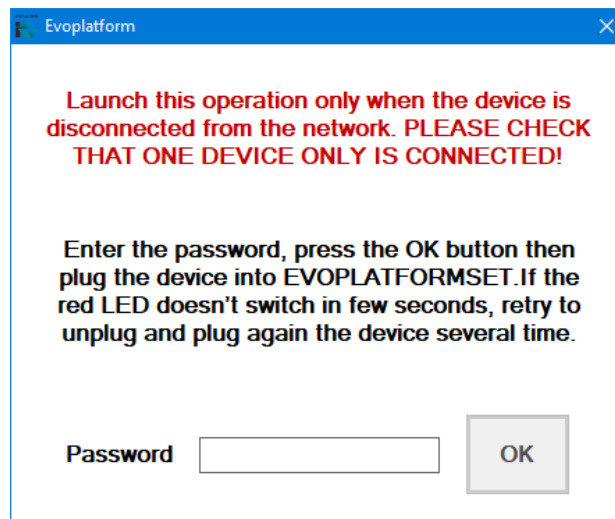

Disconnect the device from the kit and enter the password **EVO#SER!**  
Then press the OK button and connect the device to the Kit:

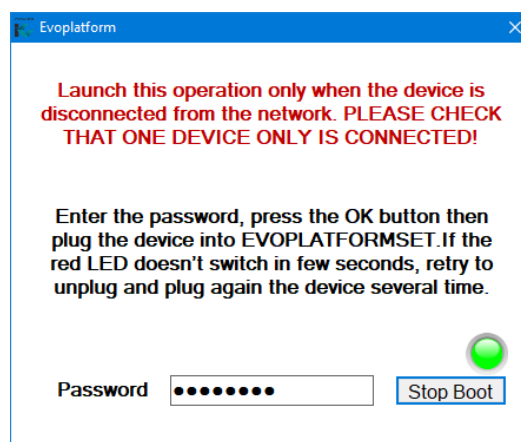

It is possible to exit this procedure by clicking on "Stop Boot" and closing the window with the "X" button  
If the Boot request is successful, the red LED lights up on the device, and the following window will appear:

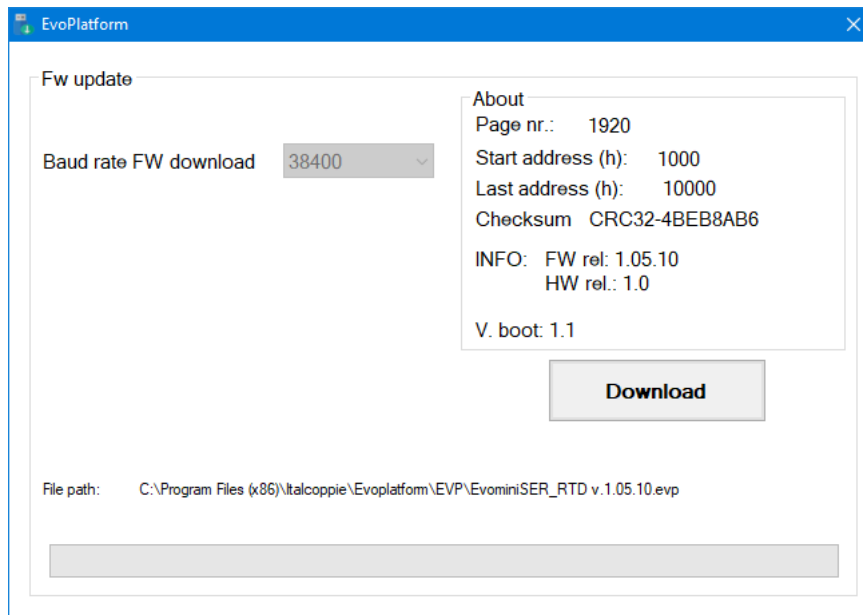

Press the "Download" button and wait for the firmware to be downloaded.  
At the end of the process the device will start automatically with the new FW



**ATTENTION:** Updating the firmware in some cases may involve restoring the factory configuration.

## 15.2 Update Firmware from BOOT(red LED on after power-on device)

If the firmware update fails, the red LED is steady on when the device is turned on. Perform the following procedure to try the firmware update again:

Open EvoPlatform, click on the EvominiSER icon and then on the "Firmware Update" icon. Load the firmware file (\*.evp) then click on "Update FW @ BOOT "

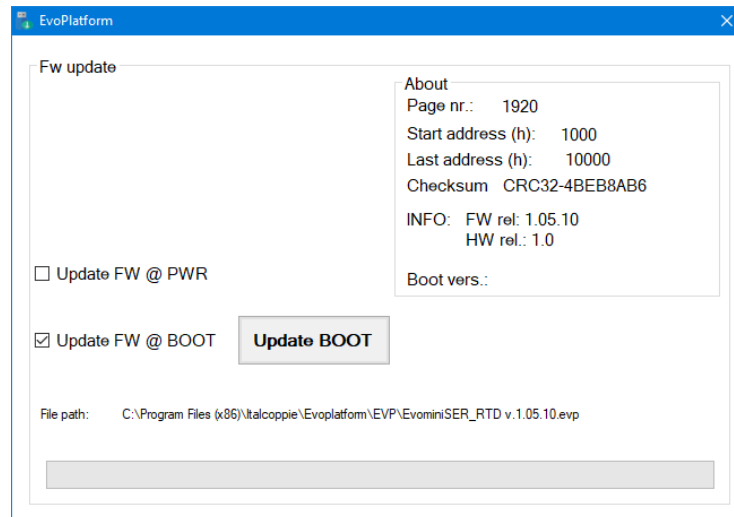

Connect the device to the PLATFORMSET and make sure that the red led is on. Click on the "Update from BOOT" button and wait for the device to be updated.



**NOTE: this option of FW update must be used with only one device connected. Thus, the device must not be connected to the Modbus network with other devices.**

Confirm with OK. Then, a password is required, as shown in Figure 27.

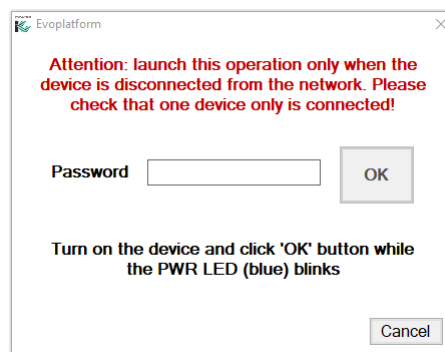

Figure 27: password request

**WARNING:** Once again, please check that is really necessary to perform this operation and that only one device is connected.

Insert the following password: **EVO#SER!**

Before confirming the password insertion with OK, power up the connected device and wait for PWR LED (blue) blinking. During PWR LED toggling, confirm with OK the password insertion.

If the operation has succeeded, the ERR LED (red) is now permanently on and the PWR LED (blue) is off. It is possible to download FW by pressing "Download", as shown in **Errore. L'origine riferimento non è stata trovata.** Wait for the end of the download and confirm the pop-up window at the end of the operation. The device will automatically restart with the new FW updated.



---

**ATTENTION: This procedure ALWAYS involve restoring the factory configuration.**

## 16 Troubleshooting

In this chapter, the most common problem and their possible solutions are described. LEDs on EvominiSER can be used to determine device status.

NOTE: if at power up LEDs are off, they have probably been disabled. Enable them by reading the device with EvoPlatform and turn to ON both led status in "Info & Setup" tab.

### 16.1 Communication errors

In case of missing communication, the following list of operations should be checked.

- 1) The master unit (e.g. PLC) must be configured with the same serial communication parameters (baud rate, Parity, number of stop bits) of the EvominiSER device
- 2) The master unit is requesting data from a Modbus address on the network that does not exist.

If the listed above has been executed but there is still a missing communication, please restore COM factory settings as described in chapter 14.1.5.

### 16.2 LEDs are off after device power up

If the LEDs on the device do not light up at power-on, check the status of the coils relating to the LEDs (Coils with address 4 and 5). Refer to chapter 11 "Modbus Coils Table"

### 16.3 ERR LED

If ERR LED is permanently on, the device is in boot mode. This happens either if the "update FW" command from tools has been sent or if device firmware is corrupted. In the latter case, it is necessary to upload the device with a new firmware. See chapter 15 for more information about this operation.

If ERR LED blinks, the non-volatile memory is corrupted or the sensor is detecting a process variable beyond the allowed limits Try use "Set default values" command (refer to chapter 14.1.5) or check if the sensor is working in the allowed ranges.. If, after device reset, ERR LED is still blinking, please contact our technical service: carefully read the instructions given in chapter 5.1.

### 16.4 PWR LED

If the device is working properly after have being turned on, the PWR LED should be permanently on. However, if PWR LED is still blinking after device initialization, an error has occurred.

If PWR LED blinks rapidly (with period less than one second), a short circuit has been detected. Immediately turn off the device. Wait few seconds and turn the device on again. If the same error is given, turn off the device and contact our technical service.

If PWR LED blinks slowly (with period of about one second), either a missing communication between the transmitter and the sensor probe or a measurement error has occurred.

---

In both cases, disconnect and connect again the probe for few times. If this will not work, restart the device. If the error is still occurring, the sensor probe might be broken and should be replaced with a new one.

**2024 ITALCOPPIE SENSORI srl**

*All rights reserved.*

*No part of this document may be reproduced or transmitted in any form, electronically or mechanically, or any purpose, without prior authorisation in writing by ITALCOPPIE SENSORI srl*

*ITALCOPPIE SENSORI srl takes the greatest pains to ensure that the information given in this document are correct. However, ITALCOPPIE SENSORI srl products are continually being improved; this may result in modifications without notification to the contents of this manual. ITALCOPPIE SENSORI srl is not liable for technical and editorial errors or omissions in the material contained herein, nor for incidental or consequential damages resulting from the supply, performance or use of this material.*

ITALCOPPIE SENSORI srl  
Via A. Tonani, 8  
26030 Malagnino (Cremona) Italy  
Tel. +39 0372-441220  
<http://www.italcoppie.com>

**Warranty:** We warrant that the products will be free from defects in material and workmanship for 1 years. The warranty above shall not apply for any failure caused by the use of the product not in line with the instructions reported on this manual.

**Product return:** the instruments can be returned under warranty only after ITALCOPPIE SENSORI srl authorization.

This product must be disposed of according to the European WEEE (Waste Electrical & Electronic equipment)

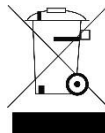

Engineered and manufactured in Italy

**Made in Italy**

Pensato, progettato e prodotto in Italia



WE SENSE  
TEMPERATURE

IMB222 Rev.4.07 October 2024